

## Infinity w/ EcoPlus Installation Instructions (INF-6, -9, -12)

### Installation Packet Includes:

Infinity w/ EcoPlus Installation Instructions  
One of three Custom EcoPlus Electrical Packets  
    Custom EcoPlus Electrical Packet (24PS HLG)  
    Custom EcoPlus Electrical Packet (HLG)  
    Custom EcoPlus Electrical Packet (Fixture Only)  
Luminous SkyTile Installation  
SkyTile Layout  
Grid Plan GR1  
Grid Plan GR2  
Electrical Layout EL1  
Electrical Layout EL2  
Grid Detail DE2  
Grid Detail DE3-5

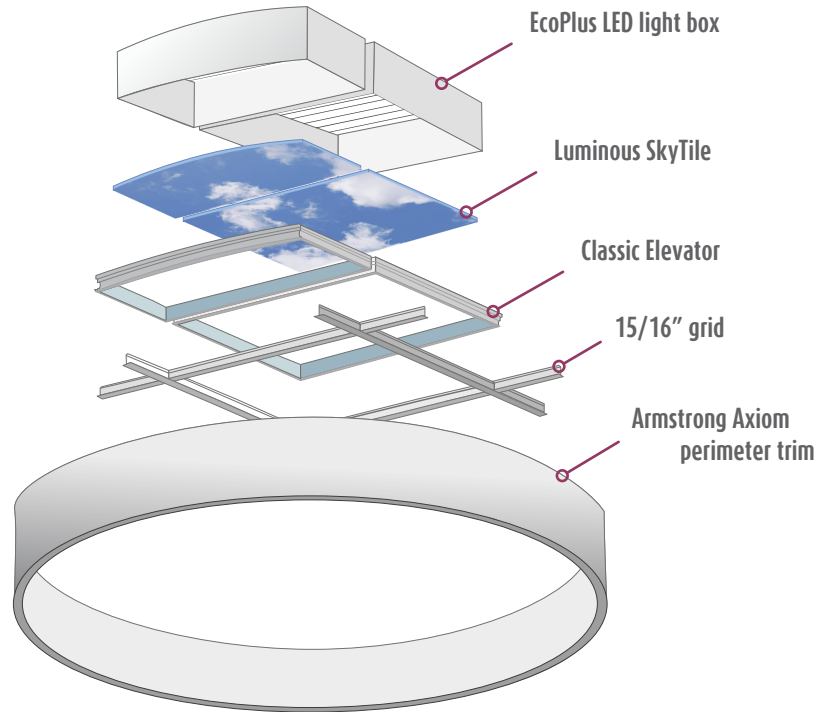

Restraint/seismic bracing not provided. For recommendations, see Appendix A on page 23.

If any of these documents are missing, please contact Sky Factory for replacements before beginning installation.

Important: All subcontractors involved must have a copy of these specifications. All specifications must be followed in all stages of on-site manufacture or installation or warranty may be voided. Any deviation in the installation specifications may alter the final product and could result in a major increase in cost. Please review all documents enclosed before installation.

For technical support at any time during the installation, please call us **toll free at 866-759-3228**.  
We want your installation to go as smoothly as possible. Thank you for choosing Sky Factory.

# Table of Contents

## Installation Requirements

Tools and Parts.....	2-5
Location Requirements.....	6
Suspension Requirements.....	7
Electrical Requirements.....	7
SkyCeiling Fixture and Suspension Details.....	8-9
Fixture and SkyTile Orientation.....	10

## Installation Instructions

Step 1: Plan for electrical.....	11
Step 2: Determine SkyTile orientation.....	11
Step 3: Transfer grid locations to perimeter trim flange....	11
Step 4: Bend grid-to-trim clips.....	12
Step 5: Attach brackets to suspension beams.....	12
Step 6: Attach suspension cables to building structure.....	13
Step 7: Hang suspension beams.....	13
Step 8a: Install mains.....	14
Step 8b: INF-9 only – Install main suspension brackets and hang.....	14

Step 9: Install cross tees.....	15
Step 10: Insert grid-to-trim clips into trim slots	16
Step 11: Install perimeter trim.....	16
Step 12: INF-12 only – Install cross-tees that join mains at trim.....	17
Step 13. Level perimeter trim/grid assembly.....	17
Step 14: Install and wire EcoPlus fixtures.....	18
Step 15: Install backer rod.....	19
Step 16: Wire fixtures to power system and dimmer (where specified).....	19
Step 17: Test SkyCeiling electrical.....	20
Step 18: Install stabilizers (or restraint/seismic bracing where required)....	20
Step 19: Close perimeter trim joints.....	20
<b>Final Inspection List.....</b>	<b>21</b>
<b>Care and Maintenance.....</b>	<b>21</b>
<b>Gripple Express No. 2 Installation Guide.....</b>	<b>22</b>
<b>Appendix A: Restraint/Seismic Bracing.....</b>	<b>23</b>

# Installation Requirements

## Tools and Parts

### Tools Provided:

- 3/32" hex wrench
- 11/32" nut driver

### Tools Needed:

- Tools to assemble installation below ceiling
- Tools to install suspension system from building structure
- 1/8" or 9/64" and 11/64" or 3/16" drill bits
- Cordless drill/driver & blind rivet tool
- Pliers, hammer, screwdrivers, measuring tape, level and other hand tools
- Tools for installing electrical and running conduit (where required)

**Parts Provided:**



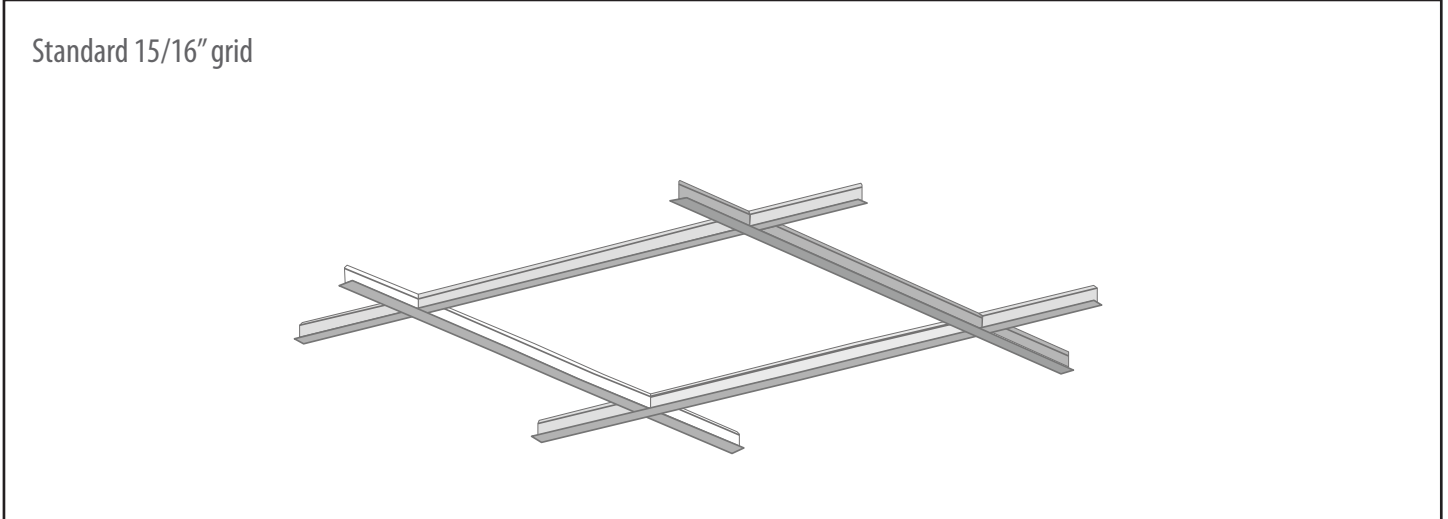
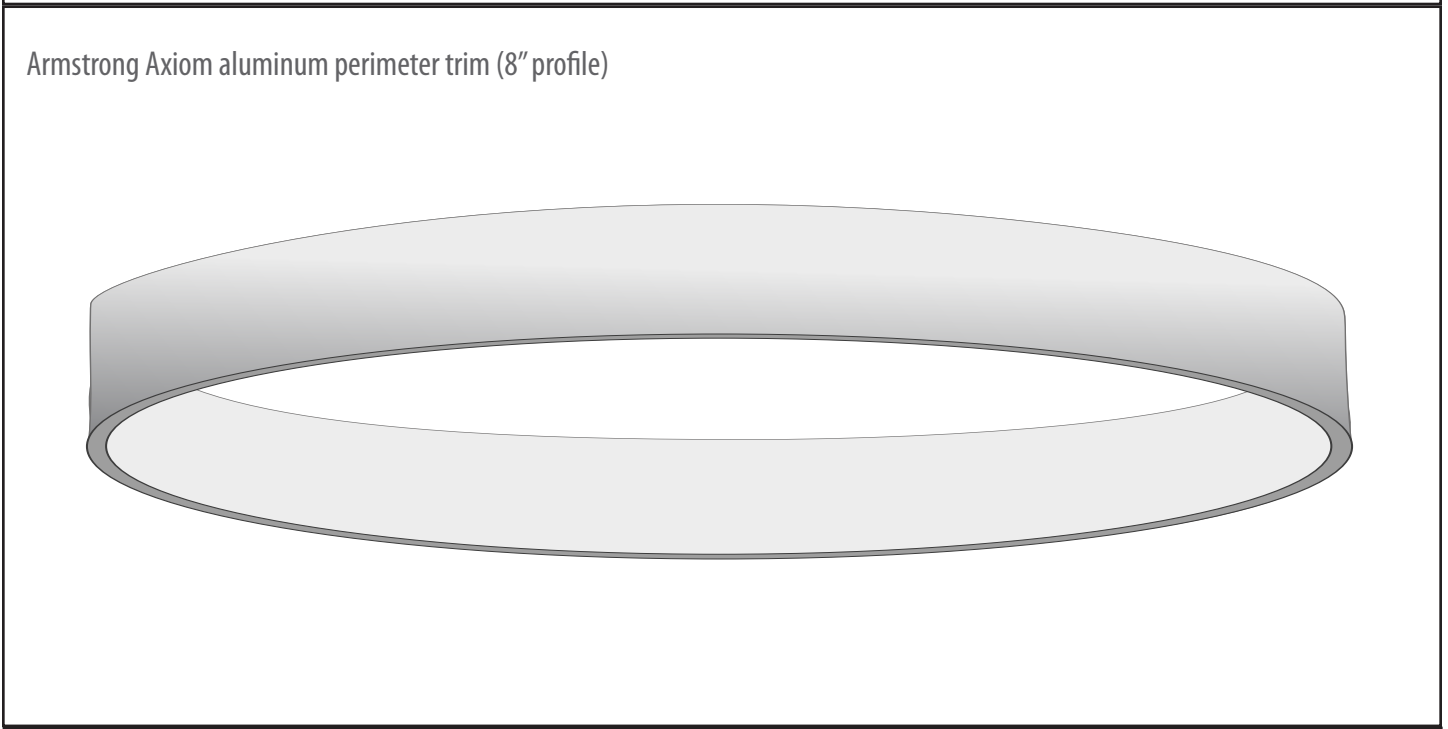
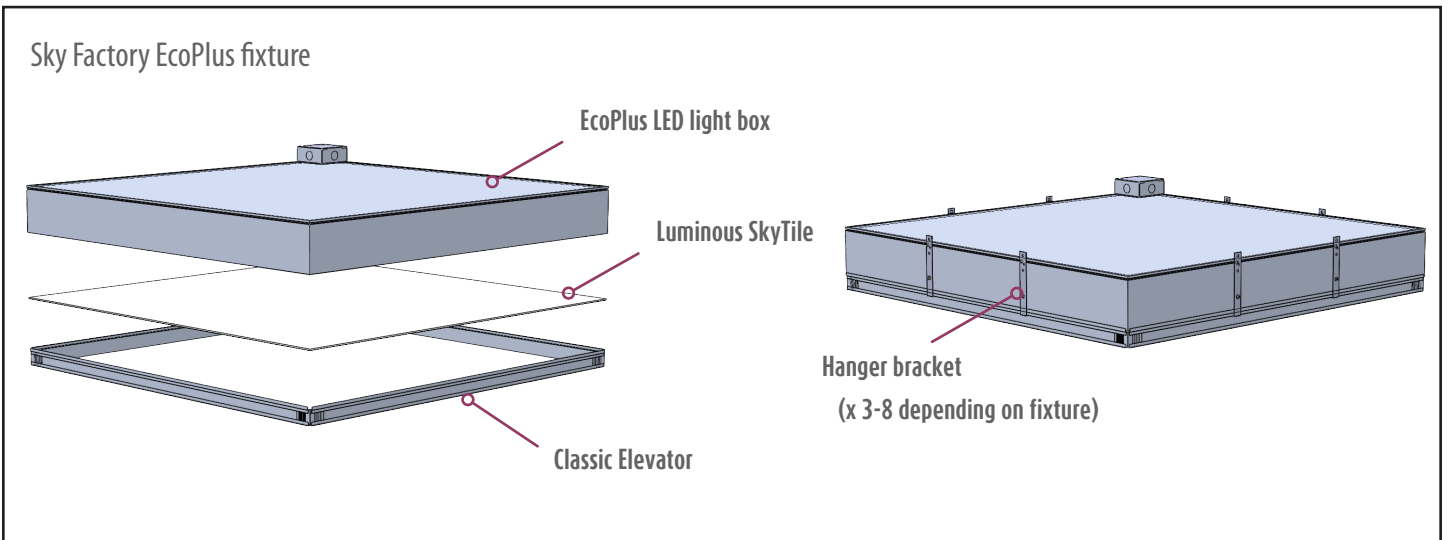

NOTE: Quantities vary depending on model

Main Components



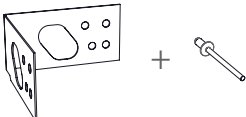

## Parts Provided (cont'd):

### Perimeter/grid/fixture hardware

<p>Perimeter trim splice plate</p> 	<p>Grid-to-trim clip</p> 	<p>Corner bracket*</p>  <p>* INF-12 only</p>	<p>Backer rod *</p>  <p>* used to center light fixtures in grid pockets</p>
--	--	--	--

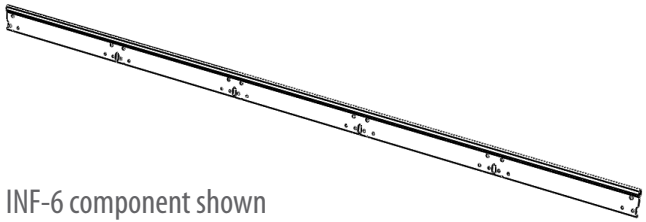
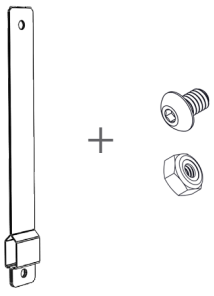
### Suspension

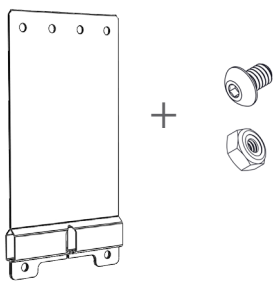
<p>Suspension beam, cut to length*</p>  <p>* INF-6 component shown</p>	<p>Suspension bracket</p>  <p>w/ 8-32 x 5/16" button head screws and Nylok's</p>
<p>Gripple Express No. 2** **</p> <p>loop type end</p>  <p>* 10' (3.1m) cable length **Comparable suspension may be used. See Suspension Requirements, page 7</p>	<p>Cross Tee/Main-to-Beam bracket</p>  <p>w/ 8-32 x 5/16" button head screws and Nylok's</p>

### Electrical

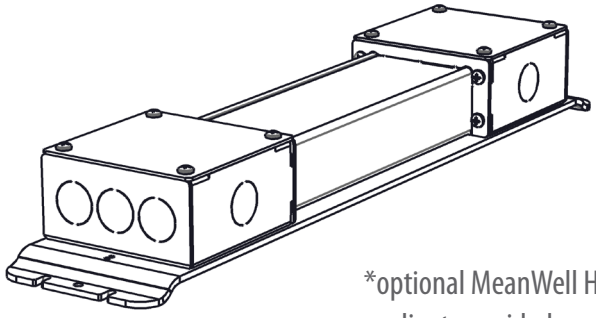
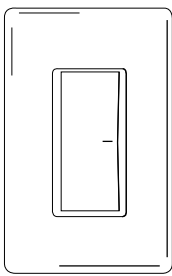
<p>Sky Factory 24PS HLG Power System*</p>  <p>*optional MeanWell HLG or client-provided</p>	<p>Dimmer switch (optional)</p>  <p>Lutron DVSTV Lutron DTV + PP-DV (North America)</p> <p>Jung 240-10 Jung 240-10 + relay (International)</p>
--	--

## Parts Needed:

for AC Source power

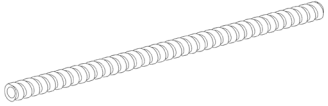
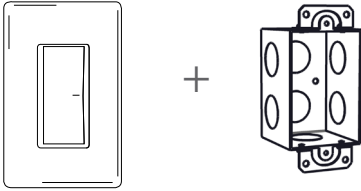
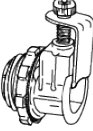
<p>Electrical wire</p> 	<p>Conduit * where required</p> 
<p>In-line switch &amp; wall box (optional)*</p>  <p>*where no dimmer is specified</p>	<p>1/2" trade size box connector*  *as per code</p> 

for DC power

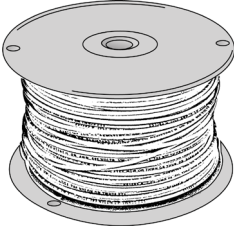
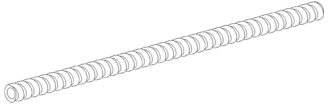
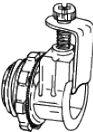
<p>Electrical wire</p> 	<p>Conduit * where required</p> 
	<p>1/2" trade size box connector*  *as per code</p> 

for suspension

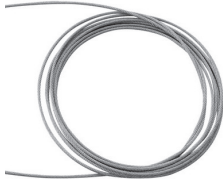
<p>Means to attach Gripples to ceiling deck</p> <p>loop end provided</p> 	<p>Flexible cable or chain to stabilize installation in ceiling space*</p>  <p>*or restraint/seismic bracing where specified See <b>Step 18</b></p>
--	--

# Location Requirements

Infinity w/ EcoPlus SkyCeiling requires selecting a location for the following components:

- SkyCeiling
- Dimmer or in-line power switch
- HLG 24PS power system

## SkyCeiling

- a minimum of 9' (2.75m) from floor to bottom of SkyCeiling recommended
- a minimum of 6" (15cm) from finished ceiling to top of SkyCeiling recommended
- suspension anchor points must meet local and national codes
- must be dry and accessible for periodic cleaning

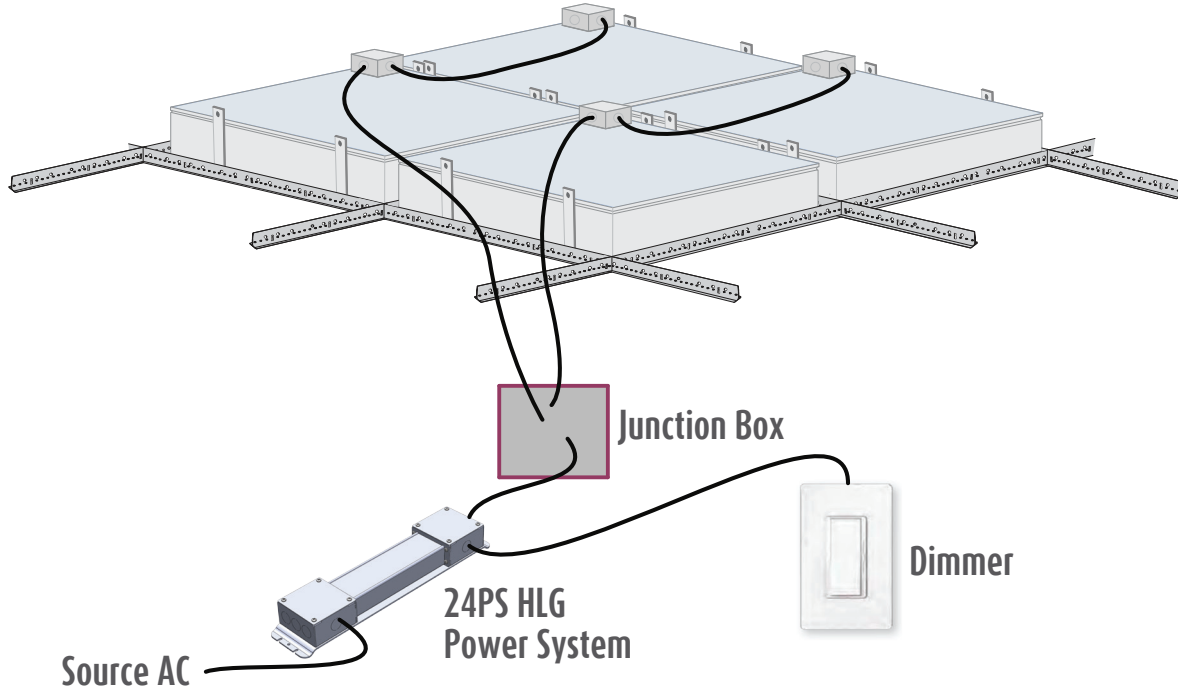

## Power system

- must be dry, dust-free and accessible for periodic cleaning
- SkyFactory 24PS HLG shown

## Dimmer

- wall box not provided
- Lutron Diva dimmer shown

# Suspension Requirements

## Fixture Suspension

Suspension system (provided) which receives Gripple Express #2 (provided) anchored to building structure:

See drawings **GR1** and **GR2** and cross sections **DE2** and **DE3-5** included.

Suspension anchor points not provided and must meet local and national codes

Alternate means to hang suspension system from building structure anchor points, if used, must meet local and national codes.

SkyCeiling must be installed level

Assembling SkyCeiling in position recommended. Assembling smaller SkyCeilings on floor and mechanically lifting into position is an option; however, caution must be taken. Infinity perimeter is a trim system and cannot be excessively torqued.

Most building codes require non-structural building components to be restrained. Sky Factory also recommends restraint in accordance with local building code requirements. Please consult with the building code professional having jurisdiction over the project to determine appropriate restraint requirements for this installation. Restraints are not included in this kit.

## SkyCeiling Dimensions and Weights

INF-6

8" (20.3cm) deep

6' 7 1/2" (202cm) outside diameter

121 lbs (54.9kg); 31lbs (14.1kg) per suspension point

INF-12

8" (20.3cm) deep

12' 8 1/2" (387.5cm) outside diameter

301 lbs (136.5kg); 26lbs (11.8kg) per suspension point

INF-9

8" (20.3cm) deep

9' 1" (277cm) outside diameter

227 lbs (103kg); 23lbs (10.5kg) per suspension point

## Electrical Requirements

See one of three electrical packets:

Custom EcoPlus Electrical Packet (24PS HLG),

Custom EcoPlus Electrical Instructions (HLG), or

Custom EcoPlus Electrical Instructions (Fixture Only)

At 24V DC:

INF-6 @ 8.0A, 190W

INF-9 @ 14.7A, 351W

INF-12 @ 29.0A, 696W

*Electrical work must be performed by a qualified electrician who is familiar with DC lighting systems and must conform to all local and national codes.*

# SkyCeiling Suspension and Fixture Details

**IMPORTANT:** Assembling SkyCeiling in position is highly recommended. Perimeter is a trim system only.  
Assembled SkyCeiling cannot be excessively torqued.

**NOTE:** Gripple suspension cables removed for clarity

1. Suspension beams suspend from building structure
2. Mains hang from beams in bracket slots
3. Cross tees hang from beams with brackets
4. Trim attaches to ends of mains and cross tees with grid-to-trim clips
5. Trim is joined with splice plates
6. Angle bracket at main, cross tee and trim junction (INF-12 only)

----- → **NOTE: INF-9** Mains, in addition to beams, suspend from building structure via brackets

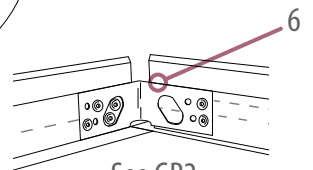
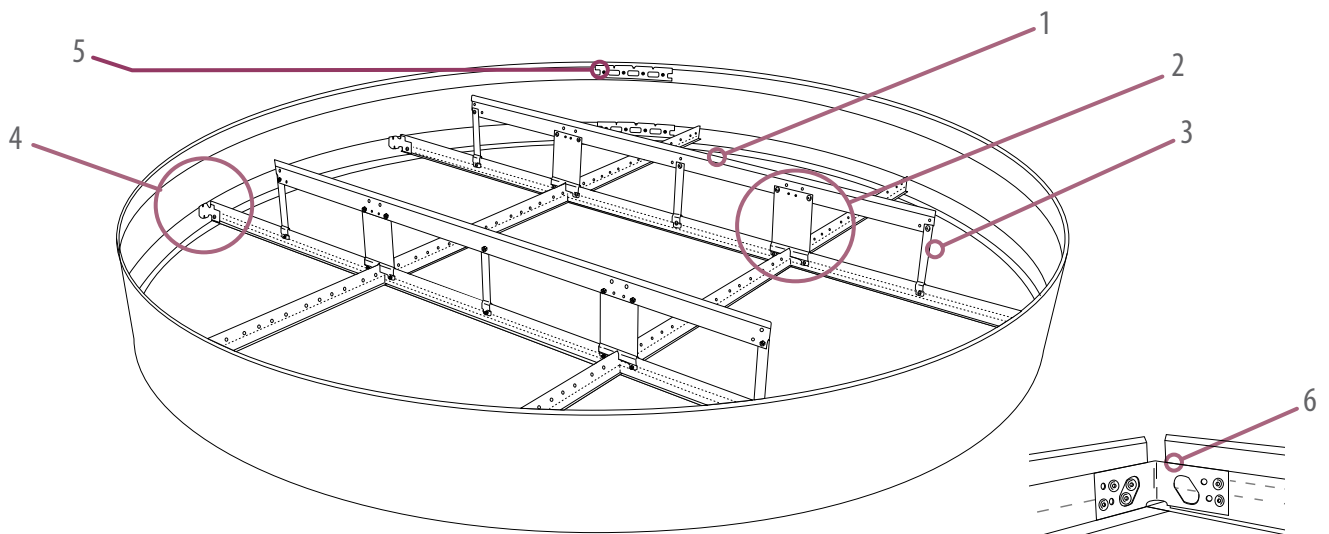

See GR2  
for Point 4 & 6 details

7. EcoPlus fixtures insert in grid pockets
8. Fixtures are wired together
9. Backer rod (as needed) centers fixtures in grid pockets

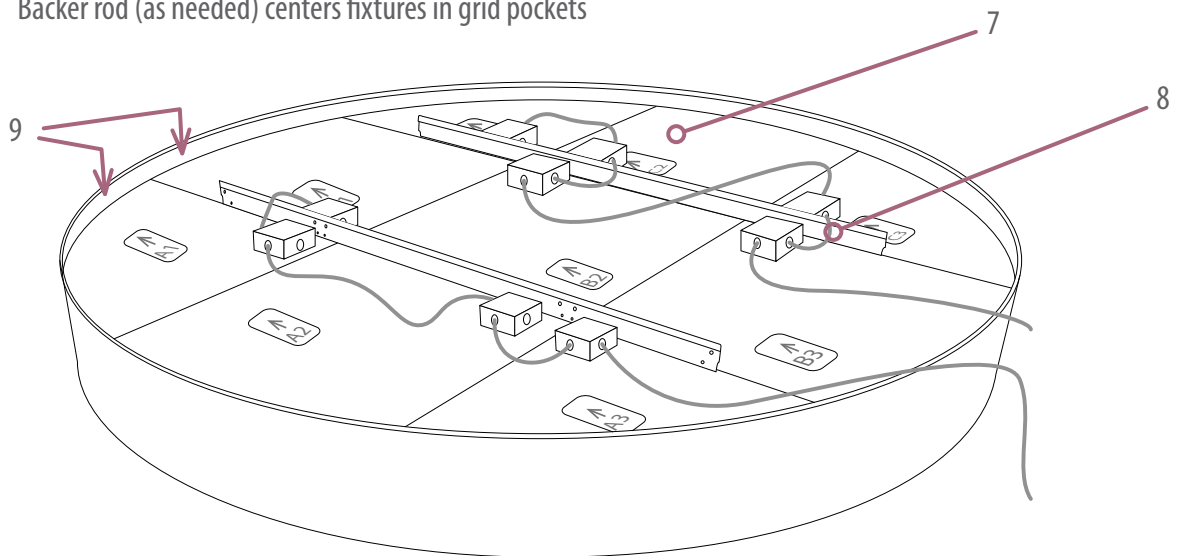

INF-6 shown

**NOTE:** Gripple suspension cables removed for clarity



**EcoPlus components:**

Hanger brackets hold fixture together and provide suspension where required.

NOTE: See page 8 for assembly details.

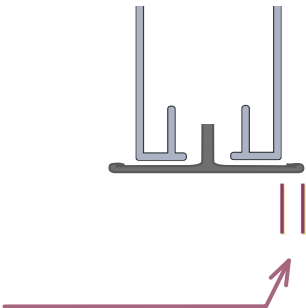
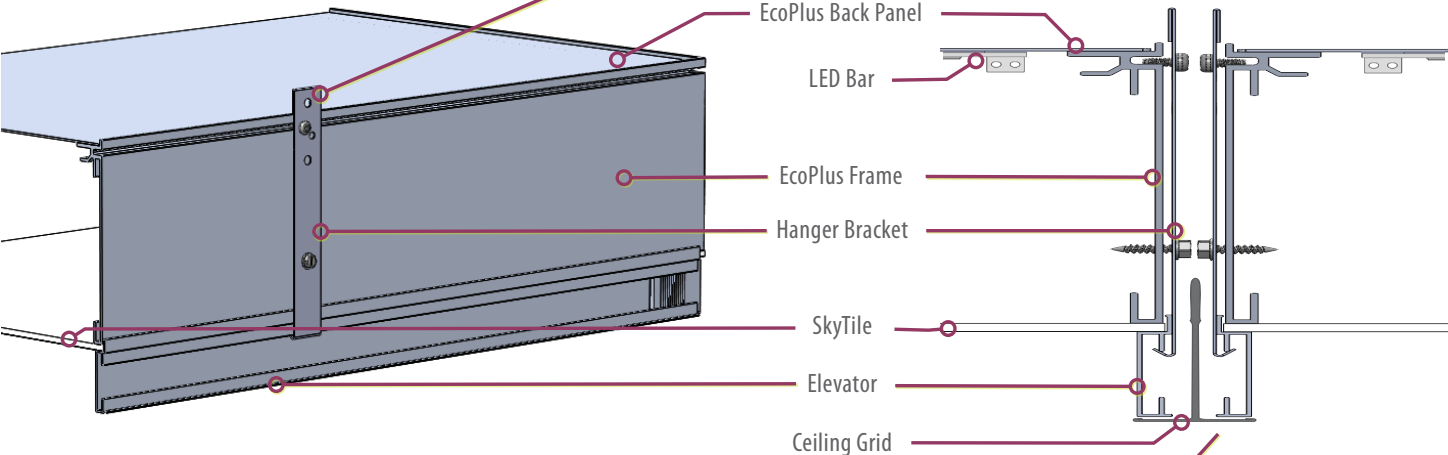
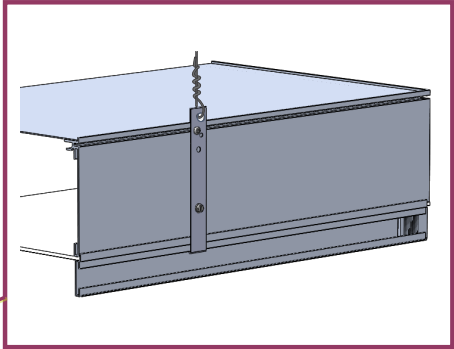

Inside face of Elevators should ideally sit:

- 1/32 inch (.79mm) back of leading edge of grid and
- 1/32 inch (.79mm) to 1/16 inch (1.59mm) back of leading edge of curved perimeter angle.

# Fixture and SkyTile Orientation

Fixtures MUST be installed so SkyTiles fit SkyTile Layout.

See **SkyTile Installation Instructions** and **SkyTile Layout** included.

To facilitate correct SkyTile placement, fixtures are labeled on top of backpan and on SkyTile:

In all installations with more than one fixture, an elevator with logo is provided.

Fixture with elevator is installed in location noted on **SkyTile Layout**.

All fixtures are location specific and are labeled accordingly.

Refer to **Grid Plan GR1** and/or **SkyTile Layout** for proper locations and orientations.

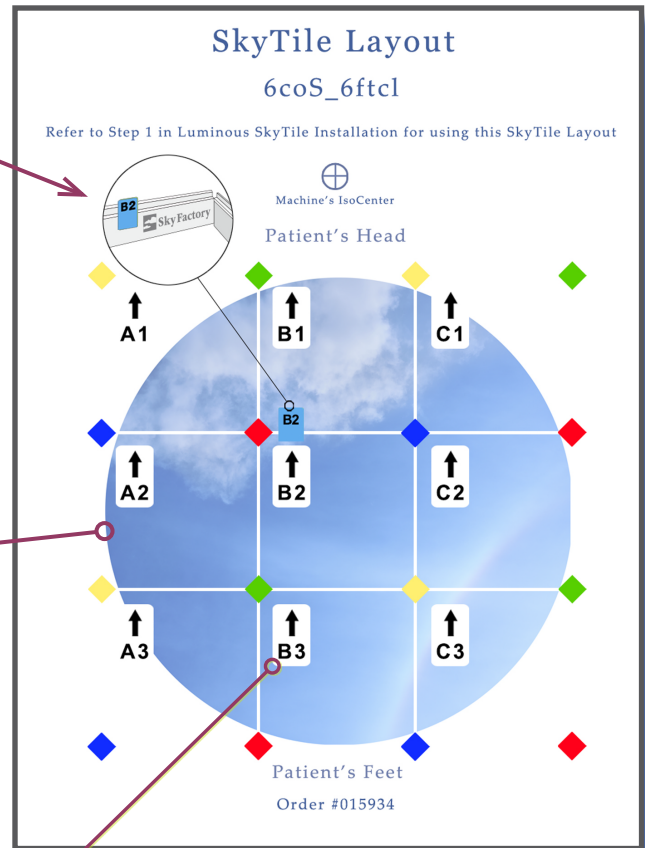

## ! Important:

Quick release labels are for installation purposes only.

They orient the location and direction of each tile in the SkyCeiling.

Labels MUST be removed once the SkyCeiling is fully installed and checked for proper orientation.

# Installation Instructions

## Step 1: Plan for electrical

- See **Location Requirements** on page 6 and **Custom EcoPlus Electrical Packet** provided

## Step 2: Determine SkyTile orientation

- See page 10
- **IMPORTANT:** Be sure to orient the fixtures following the **SkyTile Layout** sheet. If the SkyTiles are improperly oriented, the fixture or fixtures will have to be removed from the SkyCeiling so the SkyTile can be properly oriented.

## Step 3: Transfer grid locations to perimeter trim flange

NOTE: Curve of trim section may not be even and follow template; if not, gently bend to conform to curve on template. This will expedite grid and fixture installation in Steps 11-15.

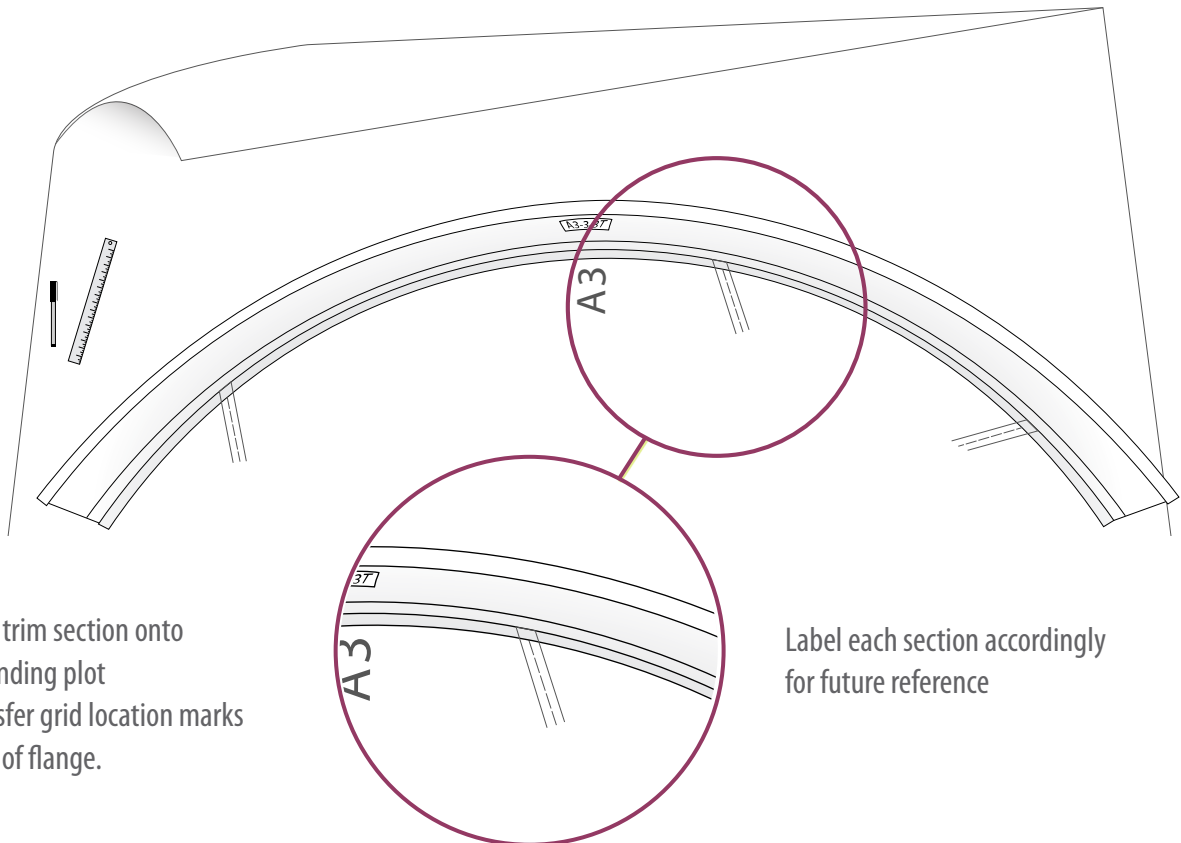

Lay each trim section onto corresponding plot and transfer grid location marks to inside of flange.

Label each section accordingly for future reference

## Step 4: Bend grid-to-trim clips

Clip inserts in lower trim slot and goes shoulder up.

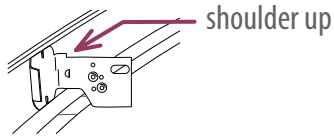

Insert at angle and twist clockwise to lock.

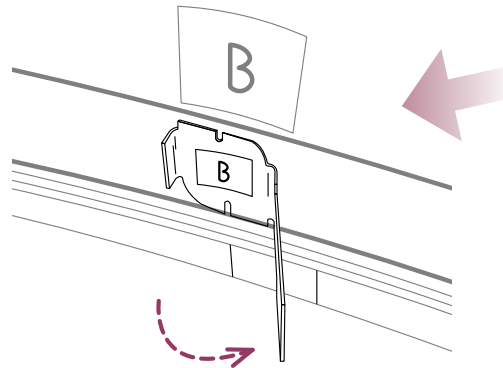

Protruding leg is bent to appropriate angle to receive grid web

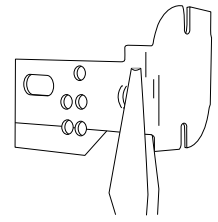

NOTE:

Leg will distort less if clip is removed and grabbed at base with needle nose

## Step 5: Attach brackets to suspension beams

See **Bracket and Suspension Detail GR2** for bracket locations and hardware details

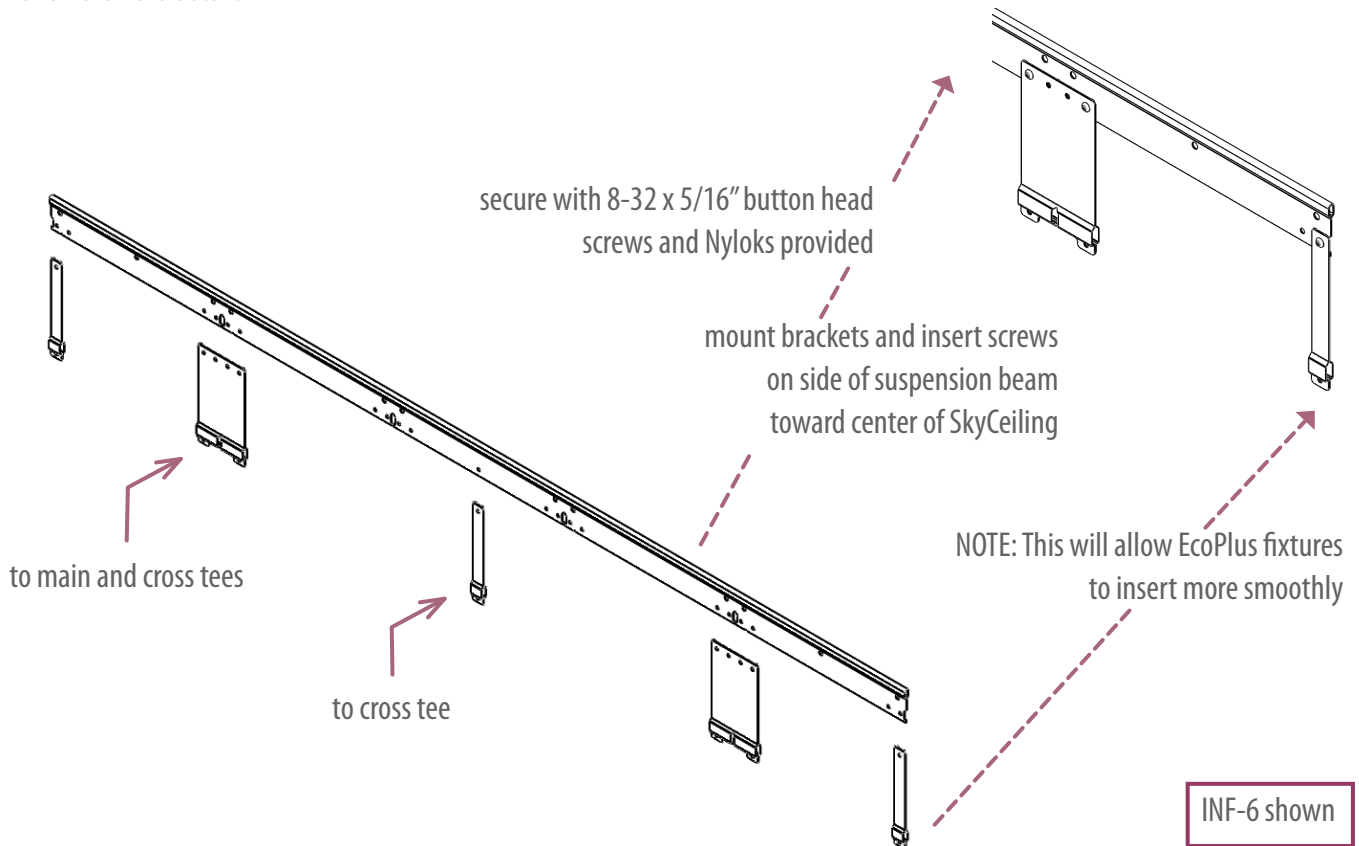

## Step 6: Attach suspension cables to building structure\*

See:

- **Bracket and Suspension Detail GR2** for SkyCeiling suspension points
- Suspension Requirements on page 7 for SkyCeiling weights
- **Gripple Express No. 2** installation sheet on page 22.
- Alternate means to hang suspension system, if used, must meet local and national codes.

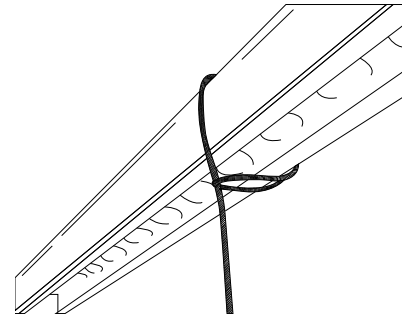

### \* INF-9 applications.

Mains require ceiling suspension as well.

See **Bracket and Suspension Detail GR2** for suspension points

See **Step 8b** for bracket installation and suspension attachment

## Step 7: Hang suspension beams

See :

- **Bracket and Suspension Detail GR2** for suspension points
- **Gripple Express No. 2** installation sheet on page 22.
- Alternate means to hang suspension system, if used, must meet local and national codes.

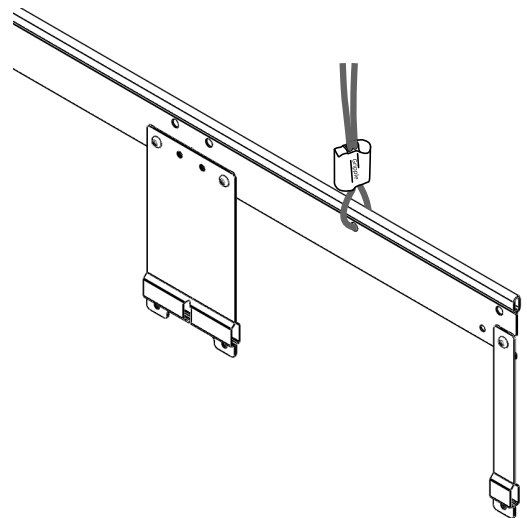

## Step 8a: INF-6, -9, -12 – Install mains

Thread mains through slots in cross tee/main-to-beam brackets

Slots in mains will line up with center of brackets:

- second slot from center of beam, and
- where applicable, fifth slot from center of beam

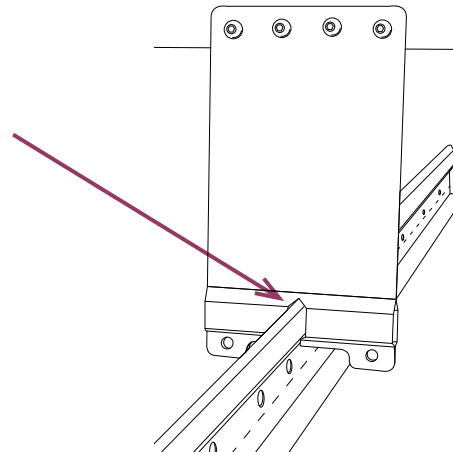

## Step 8b: INF-9 only – Install main suspension brackets and hang

After mains are threaded through cross-tee/main-to-beam brackets:

Attach brackets to mains

See **Bracket and Suspension Detail GR2** for bracket locations and hardware details

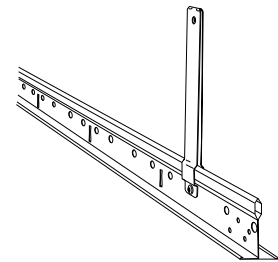

Attach brackets to ceiling suspension points

See **Bracket and Suspension Layout GR2** for suspension points and **Gripple Express No. 2** installation sheet on page 22.

Alternate means to hang suspension system, if used, must meet local and national codes.

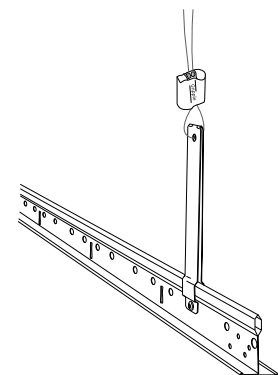

## Step 9: Install cross tees

NOTE: In INF-12 installations, some cross tees join to mains at perimeter trim intersection.

These tees must be installed after the perimeter trim. See **GR1, GR2** and **Step 12**, if applicable.

### Install uncut tees between mains first

- attach to both suspension and cross tee/main-to-beam brackets

### Install all cut tees (except tees in NOTE above) next

- attach to both suspension and cross-tee/main-to-beam brackets

### Attach tees to brackets using 8-32 x 5/16" button head screws and Nyloks provided.

- Drill 11/64-3/16" holes in grid web as needed.
- Seat bottom shoulder of bracket up against bottom of grid bulb.

### Insert all screws from center side of bracket.

- This will allow EcoPlus fixtures to insert more smoothly.

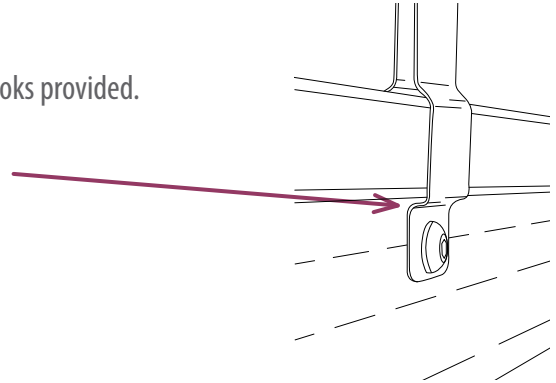

1. install uncut cross-tees

2. install all cut cross-tees not specified in NOTE above

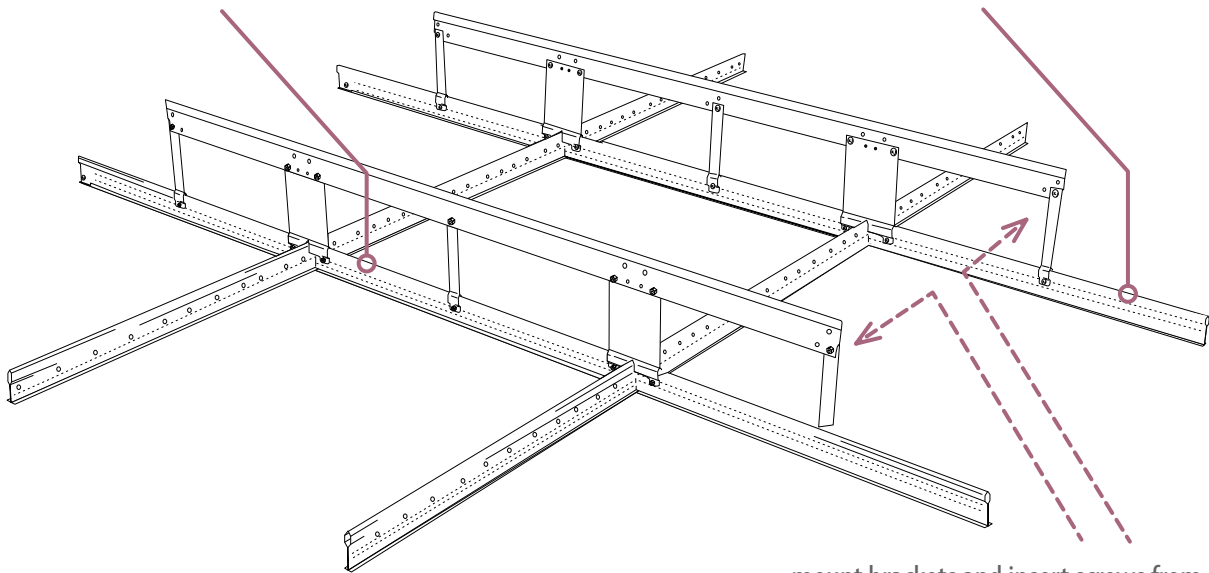

INF-6 shown

mount brackets and insert screws from center side

## Step 10: Insert bent grid-to-trim clips into perimeter trim slots

For insertion and bending details, see **Step 4**

## Step 11: Install perimeter trim

Attach trim to cut grid ends following **GR1** and **GR2**.

**IMPORTANT:** Cut grid length varies 1/16 - 1/8"

Determine grid opening on **GR1** before securing clip!

NOTE:  
See **GR2** detail  
for which side of grid  
to attach clip

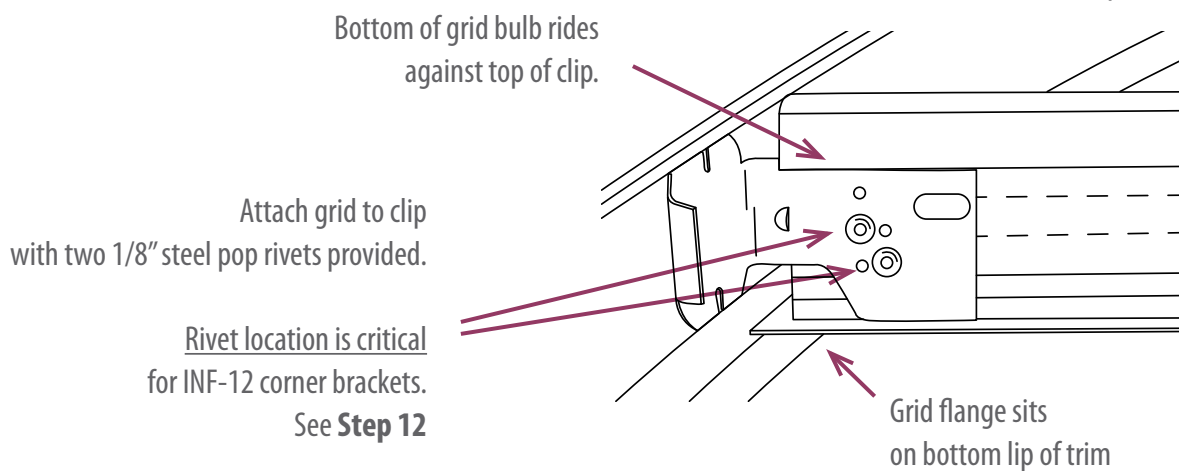

Connect trim sections with splice plates in both top and bottom slots.

Stagger plates to either side of joint

DO NOT OVERTIGHTEN SCREWS.

Excessive torque will result in deformation of trim on finished surface.

Hex wrench provided in installation kit

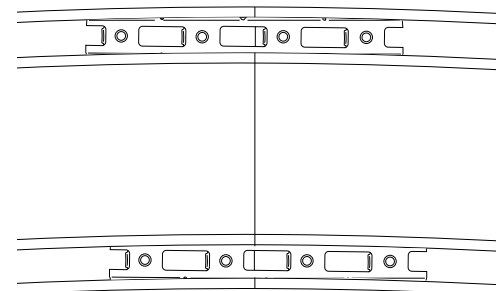



## Step 12: INF-12 only – Install cross tees that join mains at perimeter trim

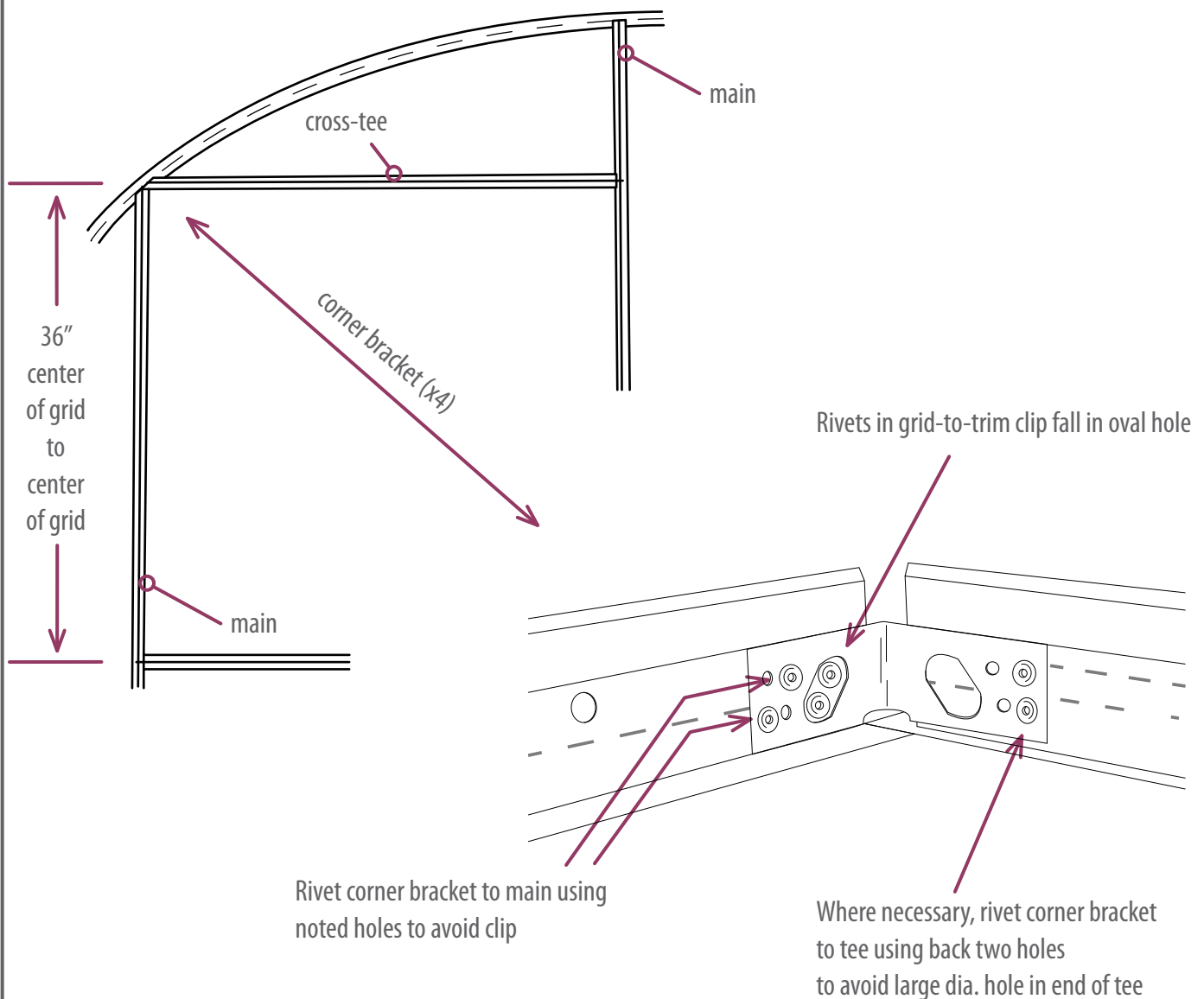

## Step 13: Level perimeter trim/grid assembly

Level the trim/grid assembly before installing the EcoPlus fixtures. Access to the assembly is easier, and adjustments, if needed, are more accessible.

## Step 14: Install and wire EcoPlus fixtures

Insert EcoPlus fixtures into appropriate grid pockets and wire fixtures together

See **GR1** and **Fixture and SkyTile Orientation** on page 10 for fixture layout and orientation

See **Custom EcoPlus Electrical Packet** for electrical instructions

### IMPORTANT:

- Fixtures in the center of the installation may need to be wired before perimeter fixtures are installed
- Do not install box connectors on side of junction box next to side of light fixture.  
It will make some fixtures difficult to install, wire, and if necessary, remove

Strongback suspension

#### 1. Install center fixtures first

- a. insert side next to suspension beam first, then
- b. drop opposing side in

Fixture may need to be wedged past suspension hardware

#### 2. Install perimeter corner fixtures next

- a. insert corner of curved side next to beam first, then
- b. drop opposing side in

Fixture may need to be wedged past suspension hardware

#### 3. Install perimeter center fixtures last

- a. insert curved side first, then
- b. drop long straight side in

Fixture may need to be wedged past suspension hardware

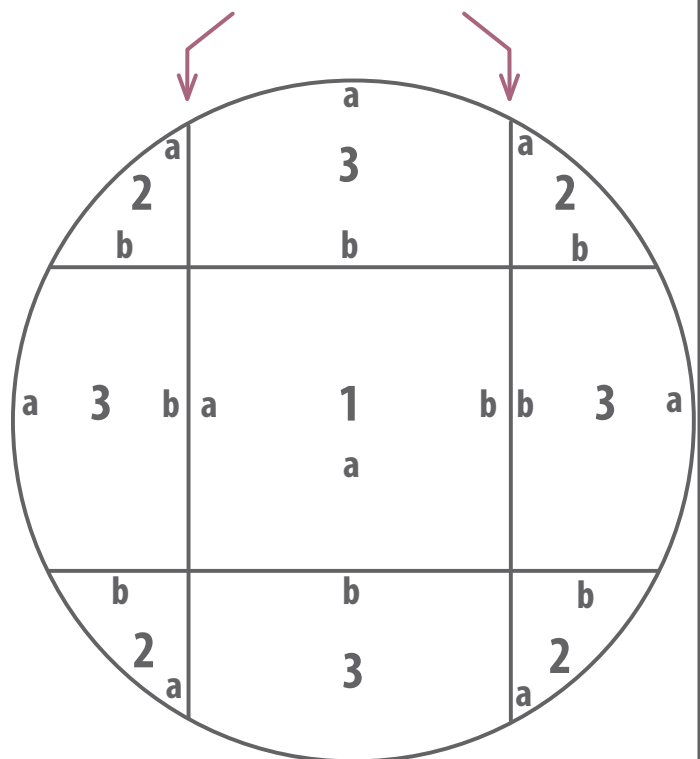

INF-6 shown

## Step 15: Install backer rod

Backer rod installs between perimeter Elevators and trim. It centers fixture in grid opening and prevents light leaks. See **DE2**.

One end of backer rod is pushed down between Elevator and trim leaving other end available at top so it can be easily removed

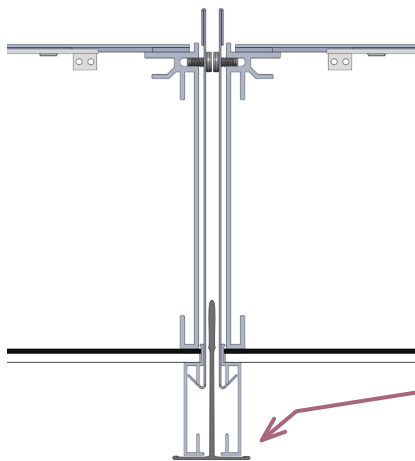
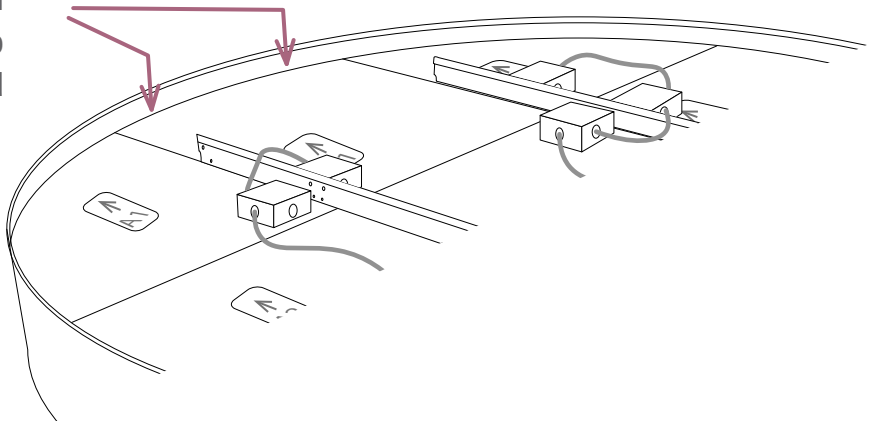

Inside face of Elevators should ideally sit:

- 1/32 inch (.79mm) back of leading edge of grid and
- 1/32 inch (.79mm) to 1/16 inch (1.59mm) back of leading edge of curved perimeter angle.

## Step 16: Wire fixtures to power system and dimmer (where specified)

See **Custom EcoPlus Electrical Packet** provided

**IMPORTANT:** Fixtures in the center of the structure may need to be wired before perimeter fixtures are installed

Install all electrical in accordance with local and national codes.

## Step 17: Test SkyCeiling electrical

Power up SkyCeiling and make sure all fixtures are on and SkyCeiling is evenly lit. If dimmer is included, make sure ceiling dims evenly.

## Step 18: Install stabilizers (or restraint/seismic bracing where required)

Skip this step and go to **Appendix A** if restraint/seismic bracing is specified

Run fine gauge flexible wire (or comparable) from end of suspension beam diagonally up to building structure to reduce sway of SkyCeiling.

## Step 19: Close perimeter joints

Perimeter joints may begin to separate from the installation process. Pull joints back together

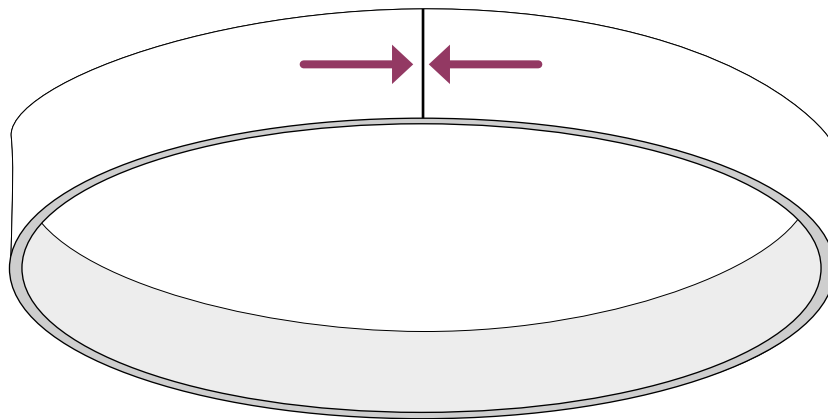

## Final Inspection List

Are all the fixtures seated down against the grid flange?

- If fixtures are not seated down against the flange, light leaks could result.

In grid ceiling applications, do all the fixtures sit evenly in the grid?

- If not, Elevator alignment may need adjusting.
- If grid is not installed square, fixtures may sit unevenly in the opening. If so, adjust grid so it is square.

Do all the fixtures sit evenly next to one another?

- If not, Elevator height or side to side position may need to be adjusted.

Is the image evenly lit?

- If there are shadows, dark spots, or bright lines on the image, clear off the back of the SkyTile.
- If one or more SkyTiles are dark, one or more fixtures are not working. Re-check wiring.

Does the SkyCeiling image match the SkyTile Layout image?

- Make sure the tiles are in the correct position and orientation. If the SkyTile Layout has a head location, make sure the SkyCeiling is properly oriented in the room. If not, they should be reinstalled.

Have the arrow-labels been removed once the image has been verified? If not, remove them now.

- Quick release labels **MUST** be removed once the SkyTiles are fully installed and checked for proper orientation.

## Care and Maintenance

- Avoid scratching SkyTiles and Elevators when cleaning.
- Once installed, SkyTiles and Elevators can be cleaned in place.
- Use mild soap and water solution, and a soft, non-abrasive cloth.
- **DO NOT** wet edges of SkyTiles. Water may cause image film to de-laminate.

# Gripple Express No.2



A push-button Gripple fastener solution for quick and easy suspension and height adjustment of light fixtures, signage, HVAC, mechanical, and electrical services, without the need for a release key.

## ADVANTAGES

- Up to 6 times faster to install than traditional methods
- Keyless - no tool required for adjustment
- Ergonomic buttons allow rapid adjustment
- Discreet and aesthetic design
- Load rated at 100 lbs with a 5:1 safety factor
- Supplied as a ready-to-use kit



## INSTALLATION

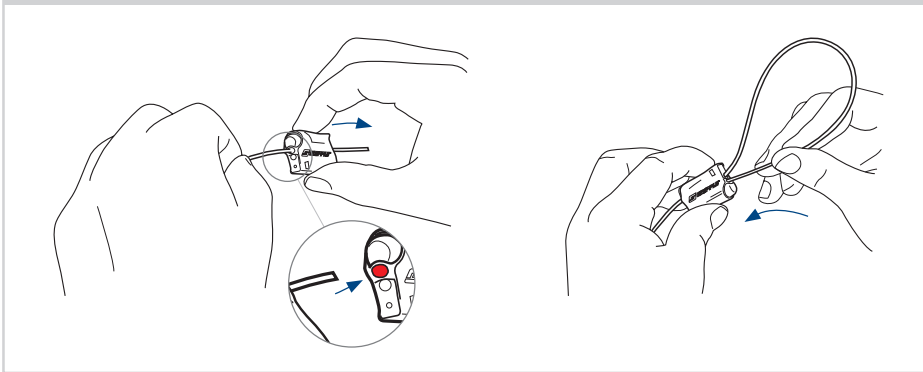

## RELEASE

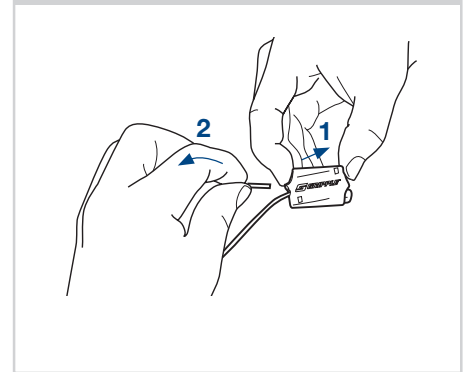

## PRODUCT DIMENSIONS

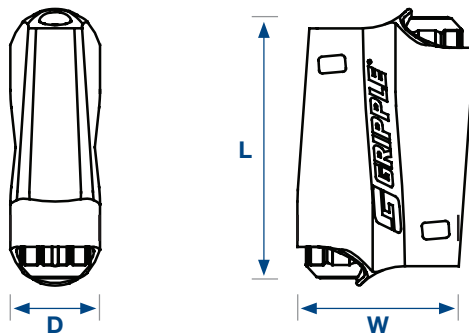

Cable Diameter	L (in)	W (in)	D (in)
5/64"	1 1/8"	7/8"	7/16"

\* This product is silicone free

## END FIXING

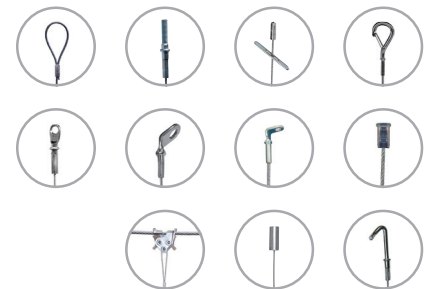

Each ready-to-use kit comes with an end fixing of your choice. Standard hanger lengths are available in 5ft to 30ft lengths; other lengths available upon request.

For further detailed information on any of our end fixings, please visit our website or contact us using the information below.

## Appendix A: Restraint/Seismic Bracing

Most building codes require non-structural building components to be restrained. Sky Factory also recommends restraint in accordance with local building code requirements. Please consult with the building code professional having jurisdiction over the project to determine appropriate restraint requirements for this installation. Restraints are not included in this kit.

Restraint for Infinity installations where anticipated seismic activity will be light (IBC seismic design categories A & B) can be accomplished by installing a pair of crossed cables 2' in from each edge of the assembly. These cables should attach to the support beams and be sloped no more than 45° from horizontal.

In areas where anticipated seismic activity will be moderate to severe, the crossed cables should be replaced with a bracing system more appropriate for the forces that will be encountered.

Testing conducted at the Structural Engineering Earthquake Simulation Laboratory, located at the State University of New York - Buffalo campus, produced satisfactory results with rigid bracing fabricated from 1/2" EMT conduit.

The tested bracing system consisted of a vertical member extending from the support beam to the structure above near each corner of the cloud. These members were positioned at the main beam/support assembly. Two additional members were fastened to the bottom of the vertical and extended to the structure at an angle not exceeding 45° from horizontal. These members were parallel to the sides of the cloud.

Restraint/bracing systems should be approved by the project design team and reviewed with local building department.