



## Luminous Virtual Window AC Recessed Installation Packet



### Installation Packet Includes:

Luminous Virtual Window AC Recessed Installation Instructions

Luminous Virtual Window Technical Specifications

Luminous Virtual Window Maintenance

LVW1 Layout (provided for custom and multiple windows)

For technical support at any time during the installation, please call us **toll free at 866-759-3228**. We want your installation to go as smoothly as possible. Thank you for choosing Sky Factory.

## Index

LVW Component Details.....	3-4
Step 1: Unpack the LVW.....	5
Step 2: Locate the LVW on the wall.....	5
Step 3: Frame the rough opening.....	6-7
Step 4: Install the LVW.....	8
Step 5: Wire the LVW .....	9
Step 6: Install the trim .....	10
Step 7: Final Checklist.....	11
Dimensions and Rough Openings Charts .....	12-13
Wiring Diagrams.....	14-15
Appendix A: Checking for Flatness .....	16

## Provided Components:

LVW Light Box: extruded aluminum case with LED edge lit light panel, internal power supplies, wiring covers and trim safety cables.

Image Tile: High resolution reproduction mounted on a .125" (3.175mm) acrylic panel.

Trim: Wood or anodized aluminum frame which attaches to the LVW case with ball catches and safety cables.

Installation Hardware: 1/2" (12.7mm) box connector, 4 #10 x 1 1/2" (38mm) pan head screws.

## Client Supplied Components:

Electrical circuit, V AC switch, conduit (if required) and wiring appropriate to local code provided and run to the appropriate locations.

For power consumption, see: LVW Technical Specifications for standard sizes, LVW1 for custom sizes

Miscellaneous hand tools

For larger LVW's, two installers may be needed.

*Electrical work must be performed by a qualified electrician and must conform to all local and national codes.*

## LVW Component Details:

### Major components:

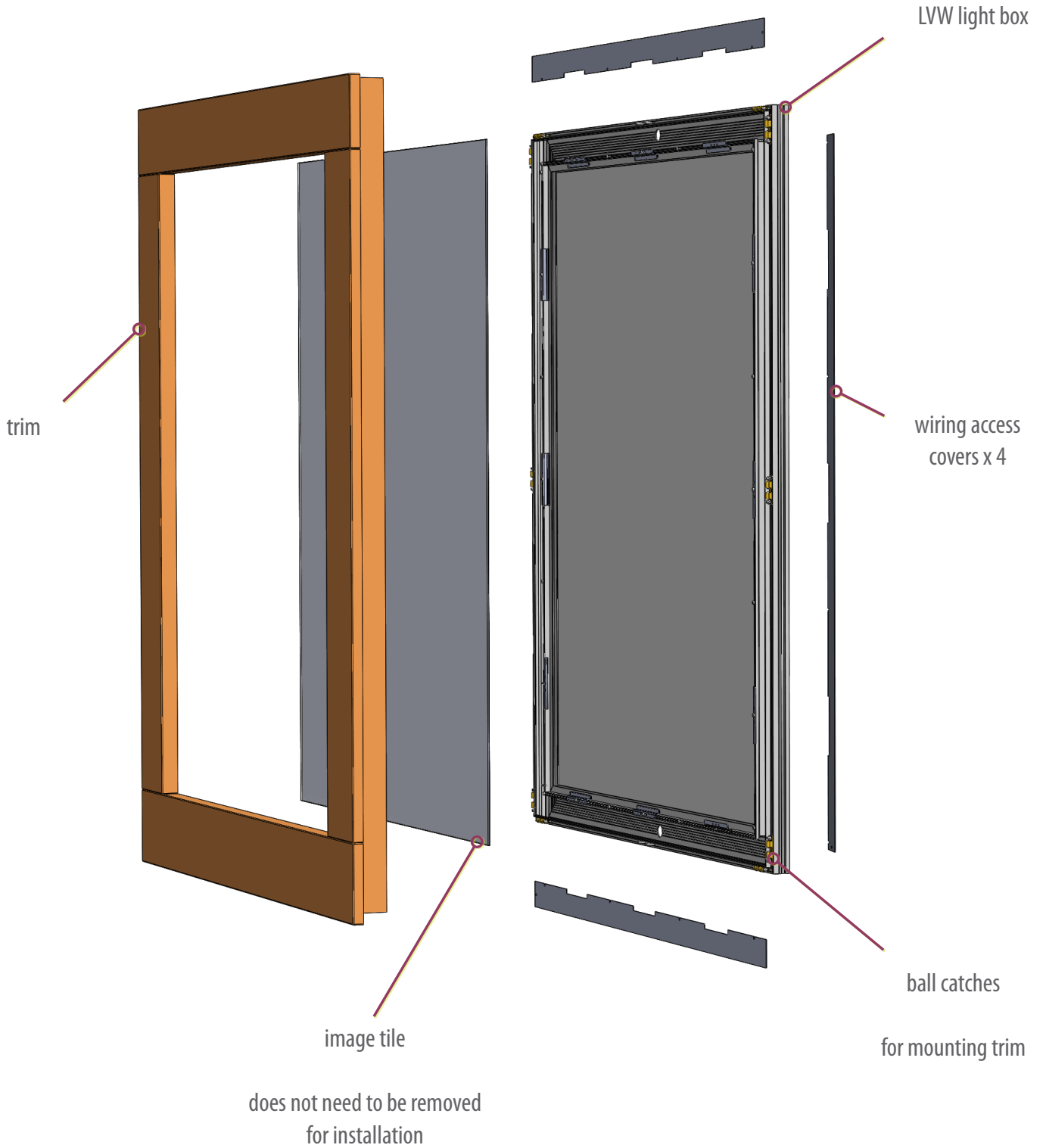

**Power supplies, attachment holes and wiring access:**

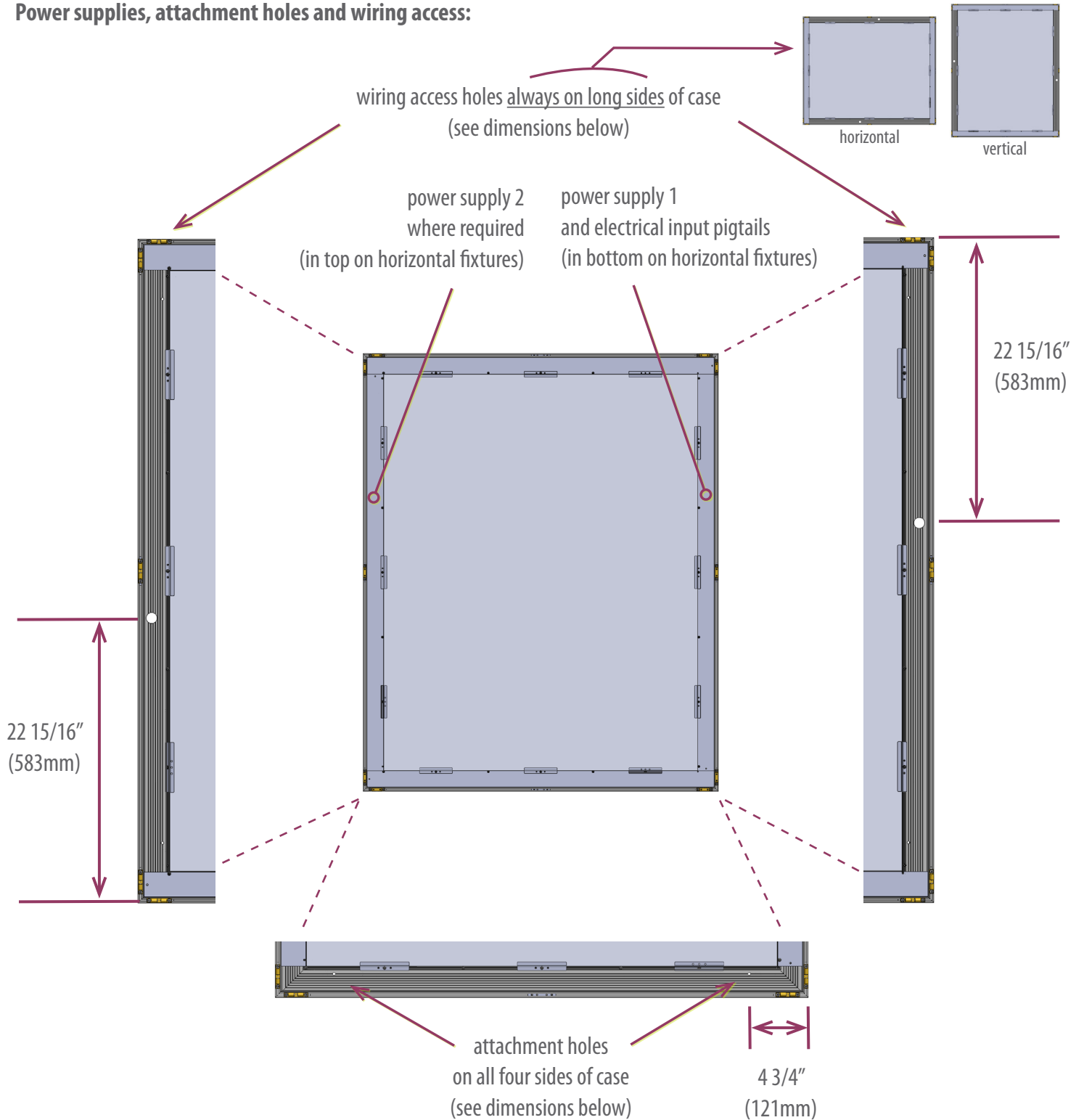

Wiring access holes — 1/2" trade size (7/8" [22.2mm] dia.), centered 1 1/6" (27mm) in from outside edge and 22 15/16" (583mm) in from end

Attachment holes — 3/16" (4.8mm) dia., centered 1 15/16" (49mm) in from outside edge and 4 3/4" (121mm) in from ends

## Step 1: Unpack the LVW

IMPORTANT: LVW comes with trim attached.

Do not try to lift the LVW out of the wrapper by pulling up on the trim.

The trim is held to the LVW case by ball-catch hardware.

To remove the trim:

remove any shrink wrap holding it to the LVW case,  
then, using both hands, grasp the trim and pull it directly away from the case.

Installation hardware is shipped above and/or along one side of the LVW(s).

## Step 2: Locate the LVW on the wall

- For all standard LVW dimensions and rough openings, see  
Luminous Virtual Window Dimensions and Rough Opening Charts on pages 12-13
- For Custom, Twin and Triple LVW installations, see “LVW1” included
- For wiring access and attachment hole locations, see page 4

We recommend the LVW is placed at standard window height.

When placing an LVW on an exterior wall, appropriate precautions must be taken to maintain the building envelope and prevent condensation from forming on or in the LVW.

### Step 3: Frame the rough opening

Rough opening height and width :  
 $3/8''$  (10mm) larger  
than outside dimensions of the LVW case.

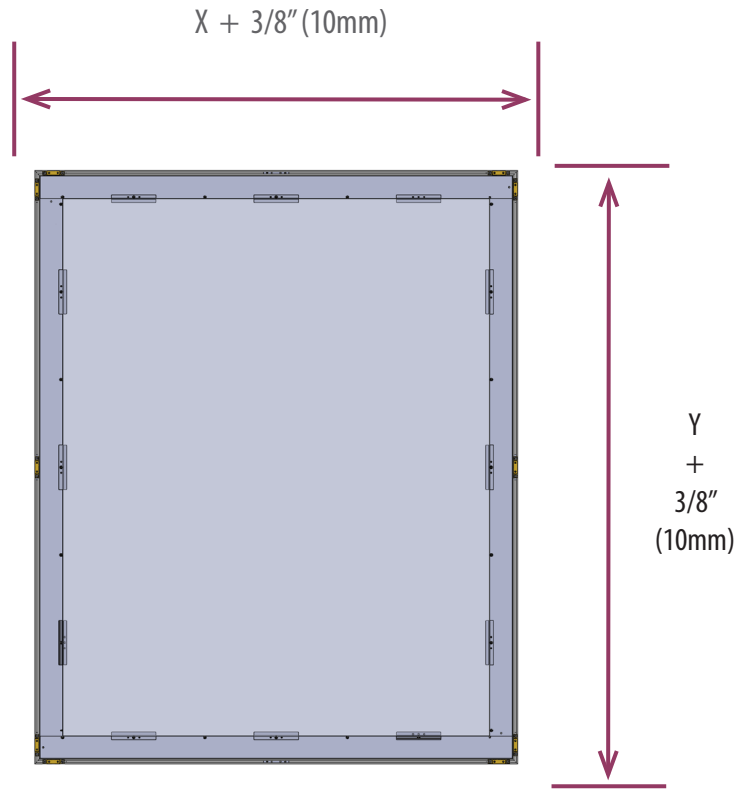

Case depth:  $1\ 3/4''$  (44.5mm).  
Added depth for box connector  
and conduit or cabling is needed

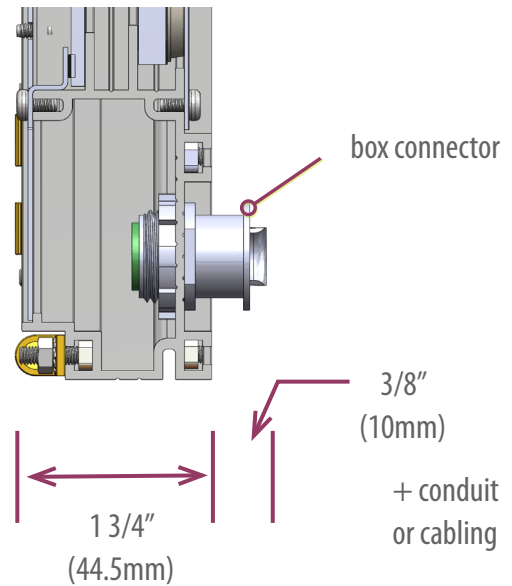

Rough opening should be plumb, square and dimensionally accurate.

Some trim selections have little overlap beyond the rough opening.

## Framing additions:

LVW is secured in the opening through holes in the back wall of the case.

See page 4 for attachment hole locations

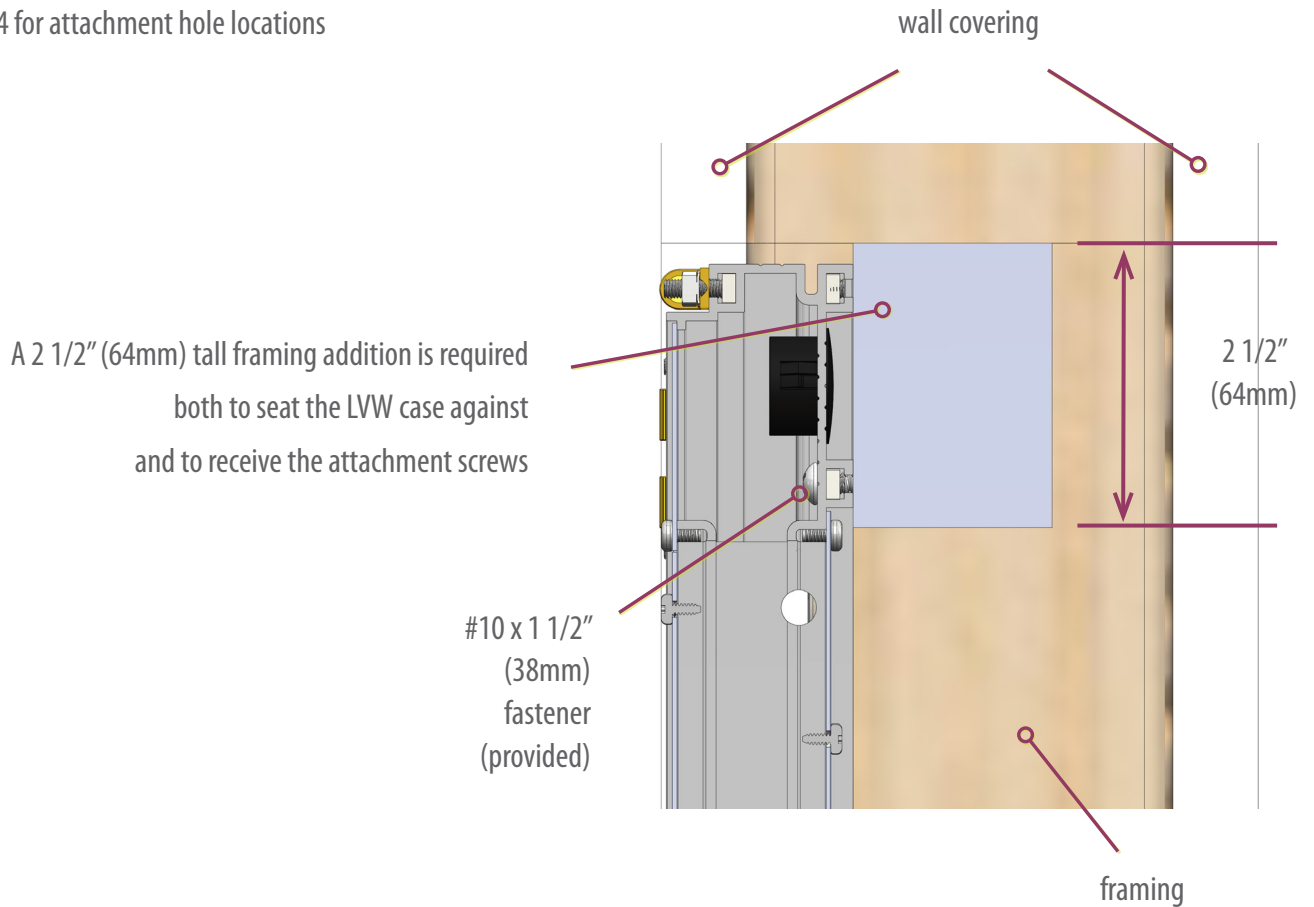

### IMPORTANT:

- Additions must sit no more than 1 11/16" (43mm) back from finish wall surface for the trim ball catches to securely latch.
- Additions must sit in a flat plane for ball catches to securely latch  
Any excessive twist in the installed LVW case may keep some of the ball catches from latching and allow the trim to pop loose.

See "Appendix A: Checking for Flatness" on page 16 for determining if the LVW will sit in a single plane.

When installing framing additions, allow for access to wiring.

## Step 4: Install the LVW

### Remove the trim (if provided):

**IMPORTANT:** Make sure the safety cables are not connected.

Trim is held by ball catch hardware. Using both hands, grasp the trim and pull it directly away from the LVW case.

### Remove the top, bottom and right side wiring covers:

Covers are secured with #6 - 32 Phillips machine screws.

Cover screws need to be loosened only.

**IMPORTANT: WHEN REPLACING THE WIRING COVERS, SNUG SCREWS ONLY!  
(OPTIONAL SCREW SLOTS ARE PROVIDED IF A SCREW STRIPS IN CHANNEL.)**

### Insert the box connector:

If using a comparable box connector, it must meet local and national codes.

See page 9 for box connector specifications.

Make sure power cable is available and enters the LVW case at the proper location.

### Hang the LVW on the wall:

Pass the power cable through the box connector while lifting the LVW into position and screwing it to the framing additions.

### **IMPORTANT:**

Before wiring the LVW, make sure the trim will securely latch.

Use a straight edge to make sure the most forward point of the wall surface is at least 1/16" (1-1.5mm) back of the front of the LVW case.

If the trim is not secure, the LVW may need to be removed and the framing additions adjusted.

See bottom of page 7.



## Step 5: Wire the LVW



### Notice:

The LED lights in the fixture are 24V DC only.

Connect V AC to **BLACK** and **WHITE** pigtails on the power supply mounted inside the case.

Connecting the V AC input to any other type of connector in the fixture will destroy the LED's.

Each LVW has internal 24 V DC power supplies pre-wired at the Sky Factory.

Each power supply is 100-277 V AC, 0.6A at 115V AC, 50/60 Hz.

For power consumption, see: LVW Technical Specifications for standard sizes, LVW1 for custom sizes

V AC power is connected to the power input pigtails:

Line power to **BLACK**, Neutral to **WHITE**, Ground to **GREEN/YELLOW** Earth pigtail.

A wiring cover must be removed to access input pigtails.

Always turn circuit off before removing a wiring cover.

#6 - 32 Phillips machine screws need to be loosened only

When replacing the cover, make sure all mounting screws are tight.

**IMPORTANT: WHEN REPLACING THE WIRING COVERS, SNUG SCREWS ONLY!**

**DO NOT OVERTIGHTEN SCREWS AND STRIP SCREW CHANNEL! (See page 8)**

Fasten the provided 1/2" (12.7mm) box connector in the 7/8" (22mm) wiring access hole and make the electrical connection inside the LVW.

Power cable must meet MC/MCI-A or HDFMCI-A specifications; size range .38" (9.65mm) min to .61" (15.49mm) max

Power entry hole is limited to 1/2" nominal trade size conduit.

Connect power (100 – 277V AC) in conformance to local and national Electrical Codes.

**Replace wiring covers and test the fixture before installing the trim.**

## Step 6: Install the trim

### Safety cables:

Safety cables catch the LVW trim if it is jarred loose of the ball catches.

Cables are mounted on the LVW case just below the top ball catch on each side.

Attaching the safety cables is easiest with two people:

One person holds the trim up while the other person attaches the quick links to the d-ring hangers on the back of the trim.

Be sure to screw the gates closed.

### Attach the trim:

Lower the trim until the ball catches line up and then press the trim against the LVW case.

Make sure all the catches latch.

### Adjusting the ball catches (if necessary):

**IMPORTANT:** Ball catches are set at the factory and should not need adjustment in the field. Use the following directions only if absolutely necessary.

To adjust the holding strength of a ball catch -

Loosen or tighten adjustment screws on the two ends of the half attached to the LVW case.

To adjust the location of a ball catch -

Loosen the Phillips head screws holding the catch to the LVW case  
slide the catch to the appropriate location in the track, and  
re-tighten the screws.

## Step 7: Check installation using Final Inspection list.



Is the image evenly lit??

- If there are shadows, dark spots, or bright lines on the image, clean the image tile. See LVW Maintenance.

Is the trim securely latched?

- If trim pops off easily, and rubs against wall when it is installed:

LVW case is most likely recessed too far into the wall. Remove LVW and shim between framing additions and back of case.

- If trim pops off easily, and there is a gap between trim and wall all the way around:

Strength of trim ball catches needs to be adjusted.

Are the safety cables installed?

- Install cables.

# LUMINOUS VIRTUAL WINDOW

## IMPERIAL DIMENSIONS AND ROUGH OPENING CHART

For custom sizes, see LVW1 included

LUMINOUS VIRTUAL WINDOW	ACTUAL CASE DIMENSIONS (INCHES)		ROUGH OPENING DIMENSIONS (INCHES)	
	WIDTH / HEIGHT		WIDTH / HEIGHT	
2240	22	40	22.375	40.375
4022	40	22	40.375	22.375
3440	34	40	34.375	40.375
4034	40	34	40.375	34.375
2852	28	52	28.375	52.375
5228	52	28	52.375	28.375
1864	18	64	18.375	64.375
6418	64	18	64.375	18.375
3464	34	64	34.375	64.375
6434	64	34	64.375	34.375
4872	48	72	48.375	72.375
7248	72	48	72.375	48.375

# LUMINOUS VIRTUAL WINDOW

## METRIC DIMENSIONS AND ROUGH OPENING CHART

For custom sizes, see LVW1 included

LUMINOUS VIRTUAL WINDOW	ACTUAL CASE DIMENSIONS (CM)		ROUGH OPENING DIMENSIONS (CM)	
	WIDTH / HEIGHT		WIDTH / HEIGHT	
2240	55.9	101.6	56.8	102.6
4022	101.6	55.9	102.6	56.8
3440	86.4	101.6	87.3	102.6
4034	101.6	86.4	102.6	87.3
2852	71.1	132.1	72.1	133
5228	132.1	71.1	133	72.1
1864	45.7	162.6	46.7	163.5
6418	162.6	45.7	163.5	46.7
3464	86.4	162.6	87.3	163.5
6434	162.6	86.4	163.5	87.3
4872	121.9	182.9	122.9	183.8
7248	182.9	121.9	183.8	122.9

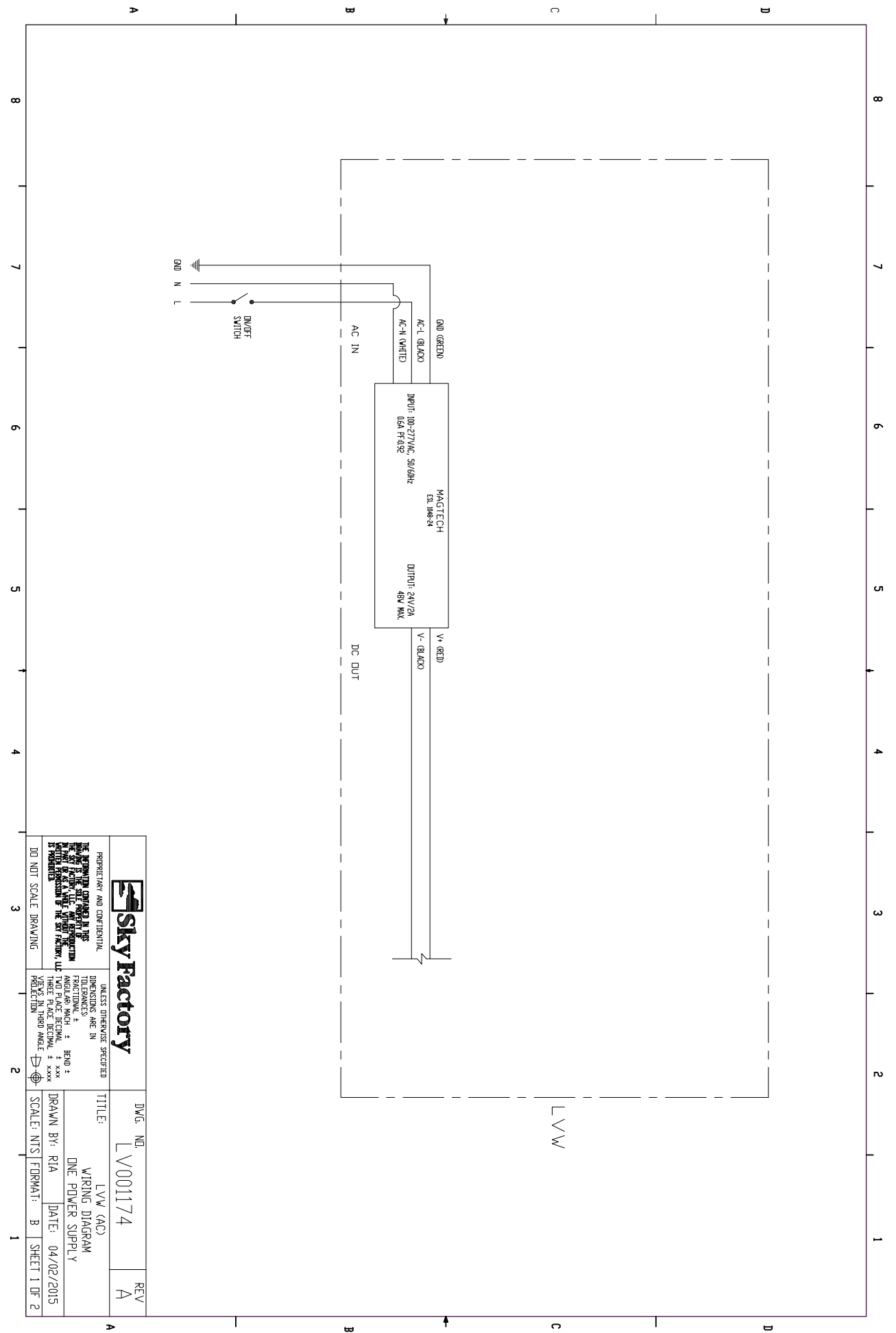

	PROPRIETARY AND CONFIDENTIAL. THE INFORMATION CONTAINED IN THIS DRAWING IS THE SOLE PROPERTY OF SKY FACTORY, LLC. ANY REPRODUCTION OR TRANSMISSION OF THIS INFORMATION WITHOUT PERMISSION OF SKY FACTORY, LLC IS PROHIBITED.	UNLESS OTHERWISE SPECIFIED DIMENSIONS ARE IN DECIMALS ± ANGULAR ± .001 TWO PLACE DECIMAL ± .001 THREE PLACE DECIMAL ± .0005 HOLE SIZE ± .001 HOLE POSITION ± .005	DWG. NO. LV001174	REV A
	DO NOT SCALE DRAWING.	TITLE: L V W (AC) WIRING DIAGRAM ONE POWER SUPPLY	DRAWN BY: RIA DATE: 04/02/2015	SCALE: NTS FORMAT: B SHEET 1 OF 2

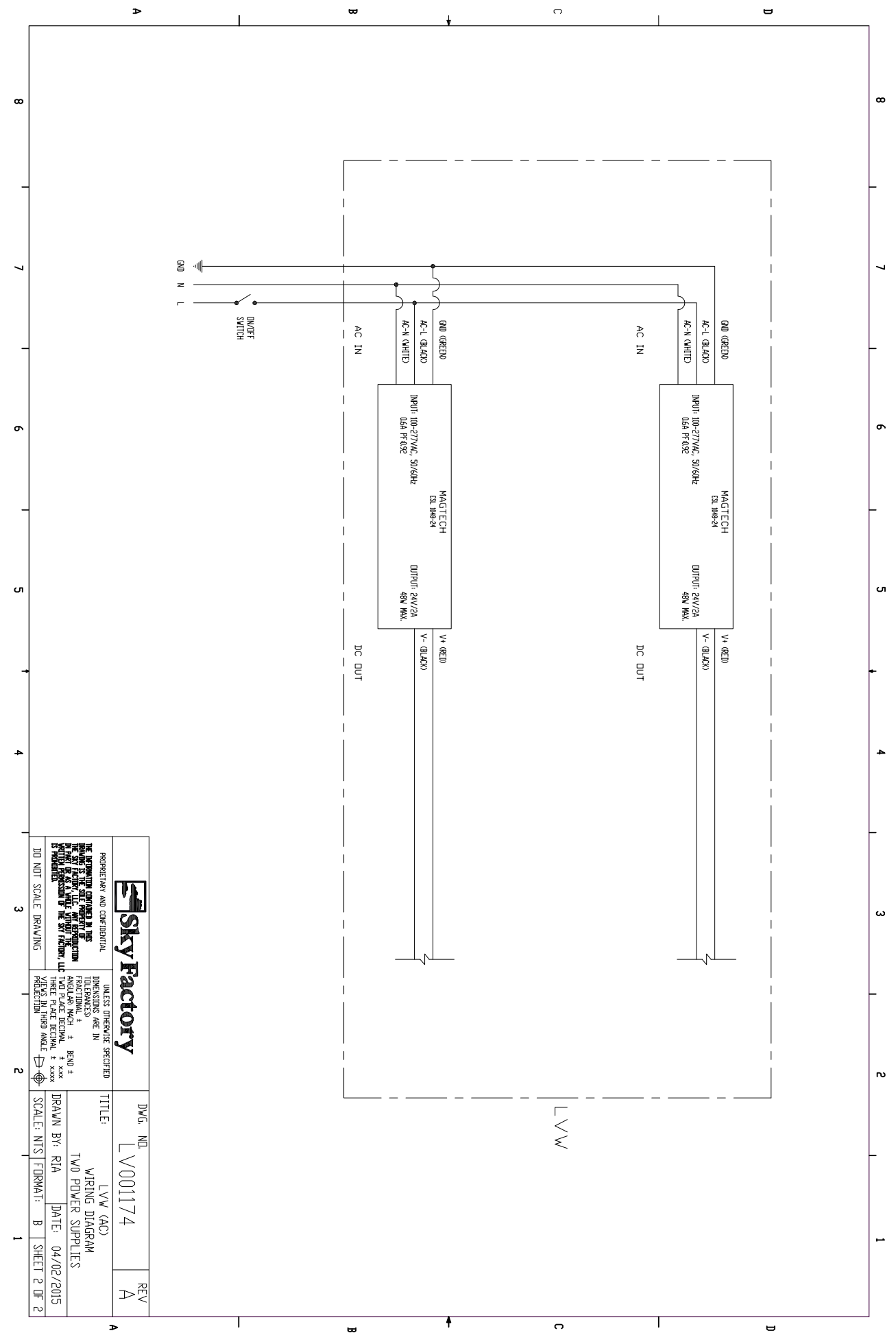

	UNLESS OTHERWISE SPECIFIED DIMENSIONS ARE IN FRACTIONAL ± ANGULAR INCH ± TWO PLACE DECIMAL ± HOLE POSITION ± HOLE DIA ± HOLE DRILL ±	DRAWN BY: RJA DATE: 04/02/2015	DWG. NO.	REV
			TITLE: L V W (AC) WIRING DIAGRAM TWO POWER SUPPLIES	L V 001174 A
PROPRIETARY AND CONFIDENTIAL THE INFORMATION CONTAINED IN THIS DRAWING IS THE SOLE PROPERTY OF SKYFACTORY AND IS NOT TO BE REPRODUCED OR TRANSMITTED IN ANY FORM OR BY ANY MEANS WITHOUT THE WRITTEN PERMISSION OF THE SKYFACTORY, LLC DO NOT SCALE DRAWING				

## Appendix A: Checking for flatness

### Making sure the LVW will sit in a single plane:

Use blocks of equal thickness to extend the framing additions out past the finished wall.

Then hold a builder's level against the blocks to make sure the two vertical sides have equal plumb.

**NOTE:** The window does not have to sit plumb in the opening to function properly, but must sit in a single plane.

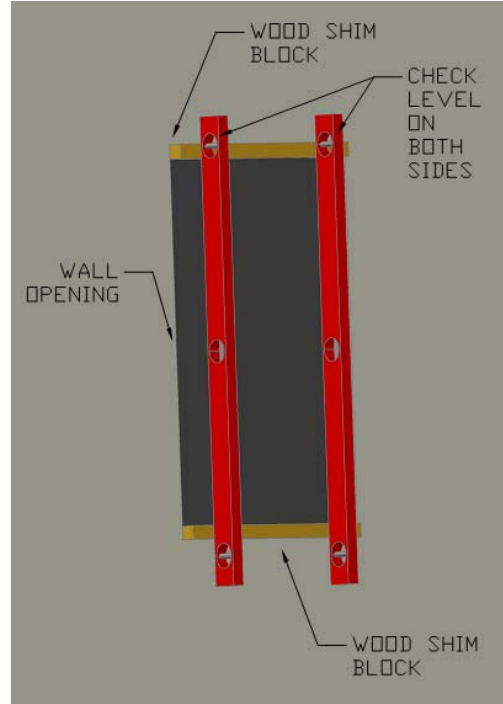

Bubbles on the builder's level must read the same for both vertical sides.

If the two sides do not read the same, re-install one of the framing additions or shim between addition and back of LVW case.

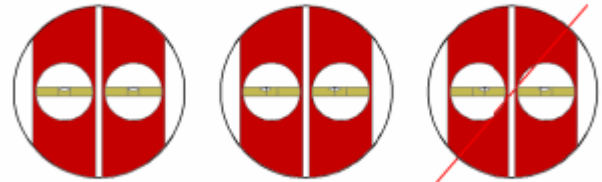

### Making sure the LVW is sitting in a single plane:

Use a builder's level against the LVW case to make sure the two vertical sides have equal plumb. Shim case as necessary.

**IMPORTANT:** Make sure level is sitting parallel to LVW case before checking for equal plumb.