



Luminous Virtual Window AC Surface Mount Installation Packet



Installation Packet Includes:

Luminous Virtual Window AC Surface Mount Installation Instructions

Luminous Virtual Window Technical Specifications

Luminous Virtual Window Maintenance

LVW1 Layout (provided for custom and multiple windows)

For technical support at any time during the installation, please call us **toll free at 866-759-3228**.
We want your installation to go as smoothly as possible. Thank you for choosing Sky Factory.

Index

LVW Component Details.....	3-5
Step 1: Unpack the LVW.....	5
Step 2: Locate the LVW on the wall.....	6
Step 3: Install the ledger brackets.....	7-8
Step 4: Install the LVW.....	9
Step 5: Wire the LVW	10
Step 6: Install the trim	11
Step 7: Final Checklist.....	12
Dimensions Chart.....	13
Wiring Diagrams.....	14-15
Appendix A: Checking for Flatness	16

Provided Components:

LVW Light Box: extruded aluminum case with LED edge lit light panel, internal power supplies, wiring covers and mounting brackets.

Image Tile: High resolution reproduction mounted on a .125" (3.175mm) acrylic panel.

Trim: Wood or anodized aluminum frame which attaches to the LVW case with ball catches and safety screw.

Installation Hardware: 1/2" (12.7mm) box connector, mounting bracket hardware

Client Supplied Components:

Electrical circuit, V AC switch, conduit (if required) and wiring appropriate to local code provided and run to the appropriate locations.

For power consumption, see: LVW Technical Specifications for standard sizes, LVW1 for custom sizes

Miscellaneous hand tools

For larger LVW's, two installers may be needed.

Electrical work must be performed by a qualified electrician and must conform to all local and national codes.

LVW Component Details:

Major components:

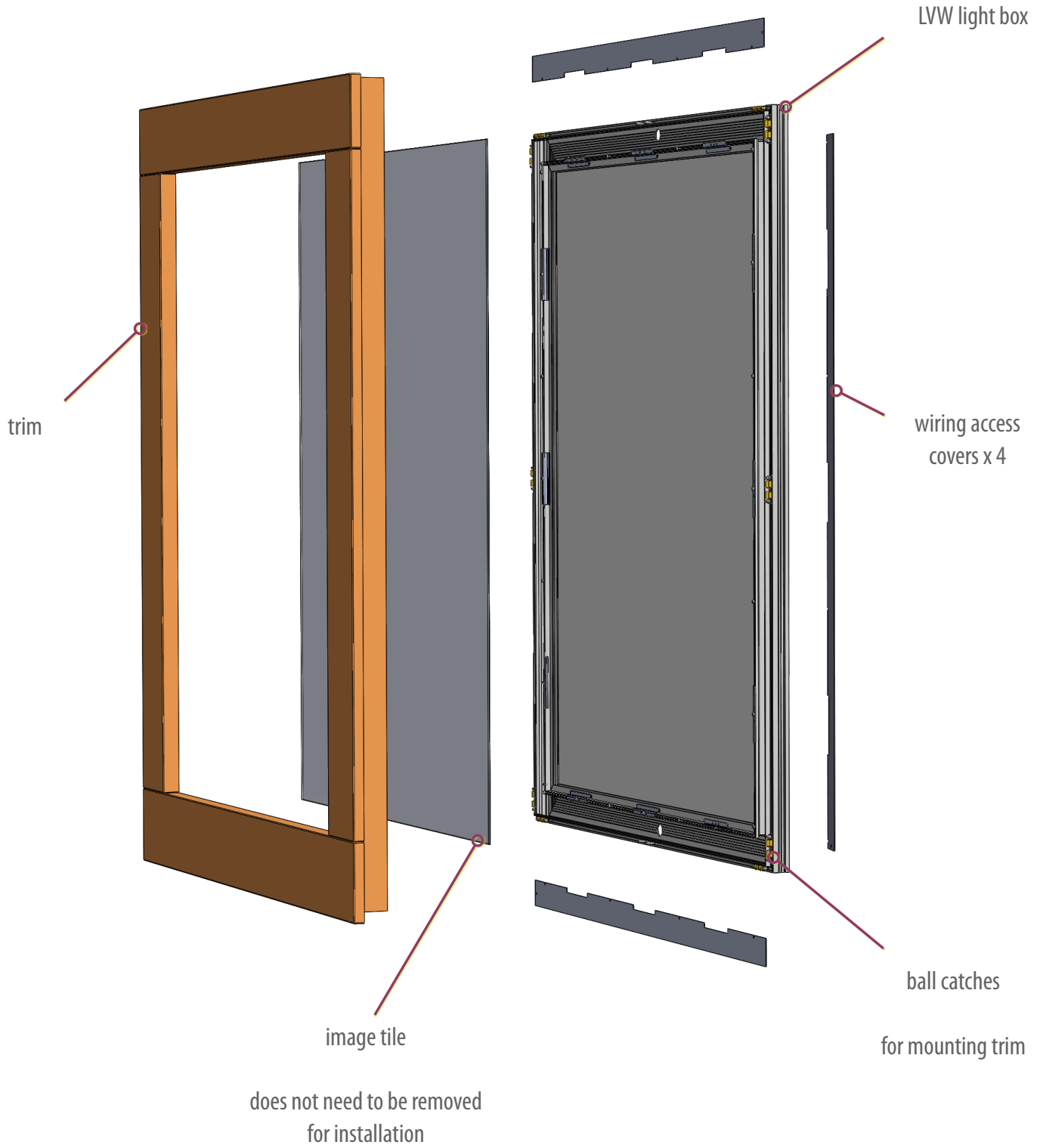

Power supplies, attachment holes and wiring access:

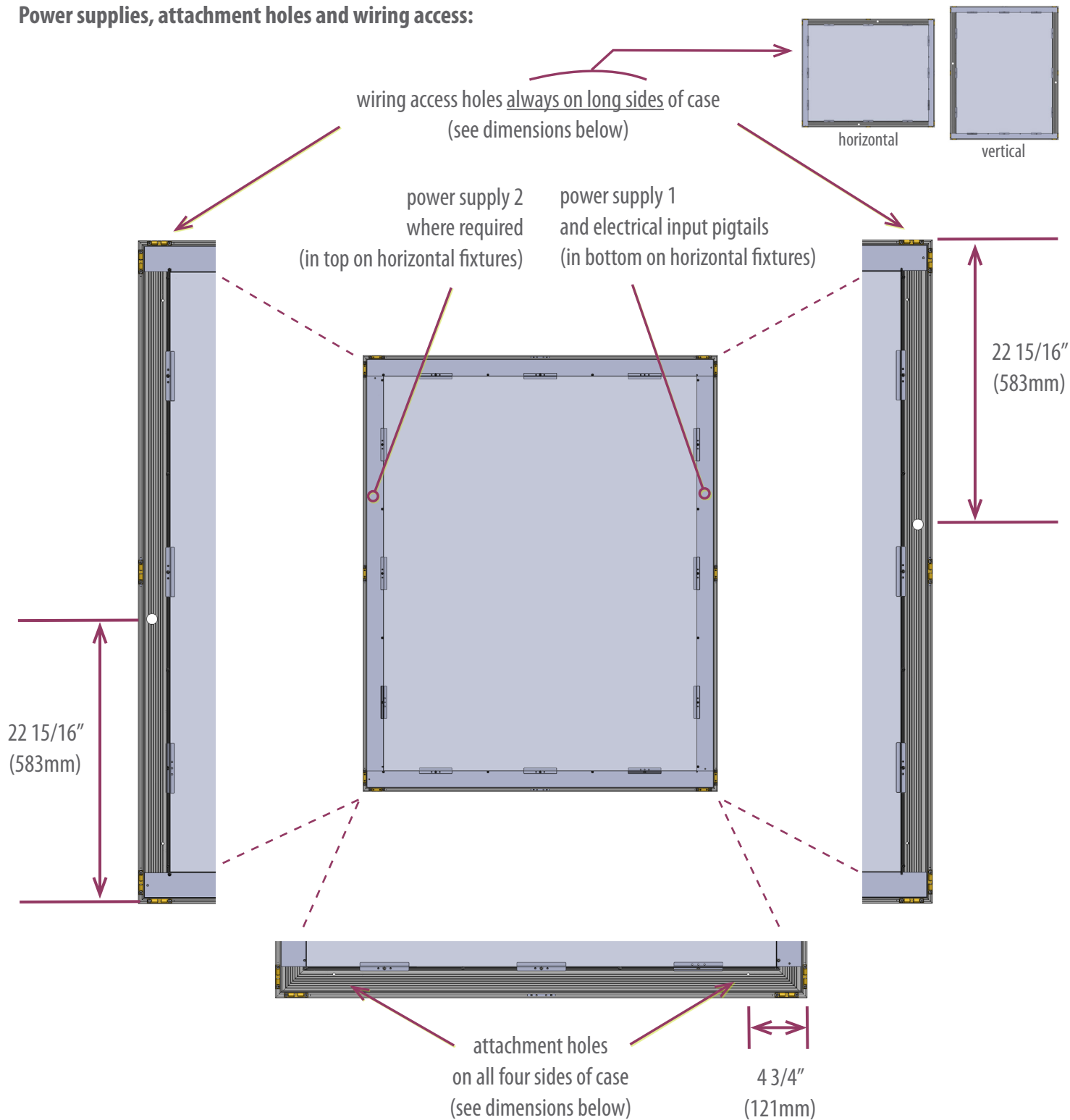

Wiring access holes — 1/2" trade size (7/8" [22.2mm] dia.), centered 1 1/6" (27mm) in from outside edge and 22 15/16" (583mm) in from end

Attachment holes for locking mounting brackets only —

3/16" (4.8mm) dia., centered 1 15/16" (49mm) in from outside edge and 4 3/4" (121mm) in from ends

IMPORTANT: For stabilizing mounting brackets only; do not use for weight bearing. See Step 4

Mounting brackets:

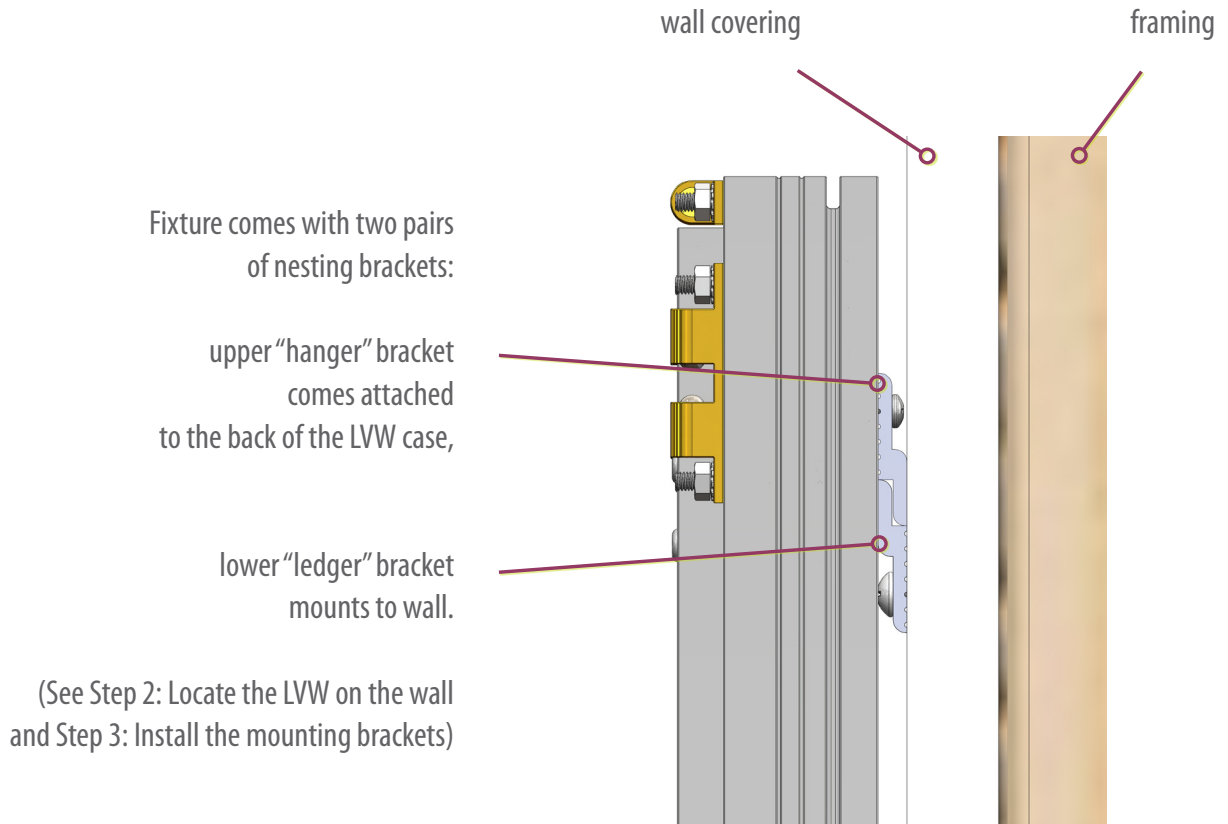

Step 1: Unpack the LVW

IMPORTANT: LVW comes with trim attached.

Do not try to lift the LVW out of the wrapper by pulling up on the trim.

The trim is held to the LVW case by ball-catch hardware.

To remove the trim:

remove any shrink wrap holding it to the LVW case,
then, using both hands, grasp the trim and pull it directly away from the case.

Installation hardware is shipped above and/or along one side of the LVW(s).

Step 2: Locate the LVW on the wall

- For all standard LVW dimensions and rough openings, see Luminous Virtual Window Dimensions Chart on pages 13
- For Custom, Twin and Triple LVW installations, see "LVW1" included
- For wiring access and attachment hole locations, see page 4-5

We recommend the LVW is placed at standard window height.

Where possible, always attach top ledger bracket to at least two studs.

See Step 3, pages 7-8

Where only one stud is available, bracket preferably centered on stud with a 3/16" (9.5mm) toggle bolt at each end.

When placing an LVW on an exterior wall, appropriate precautions must be taken to maintain the building envelope and prevent condensation from forming on or in the LVW.

Adequate room for box connector and cabling to penetrate the wall covering will be required.

Case depth: 1 3/4" (44.5mm).

Added depth for box connector and conduit or cabling is needed

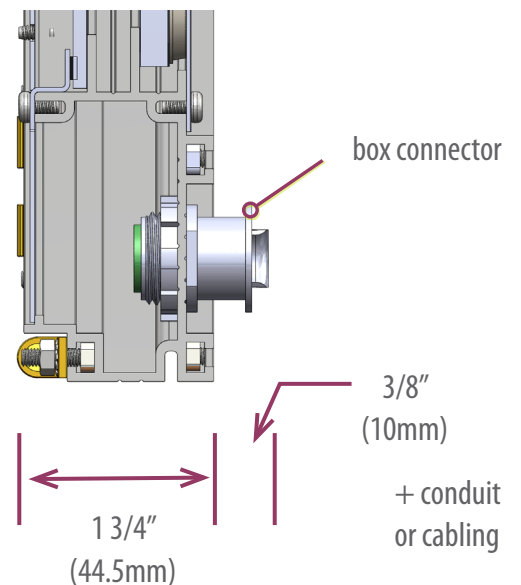

Step 3: Install the ledger brackets

See also wall layout detail on next page.

"Hanger" brackets are pre-mounted on back of fixture:

On vertical fixtures (in which sides are longer):

Top and bottom brackets are continuous

On horizontal fixtures (in which sides are shorter):

Top bracket is continuous;

bottom bracket is split to accommodate wiring access hole

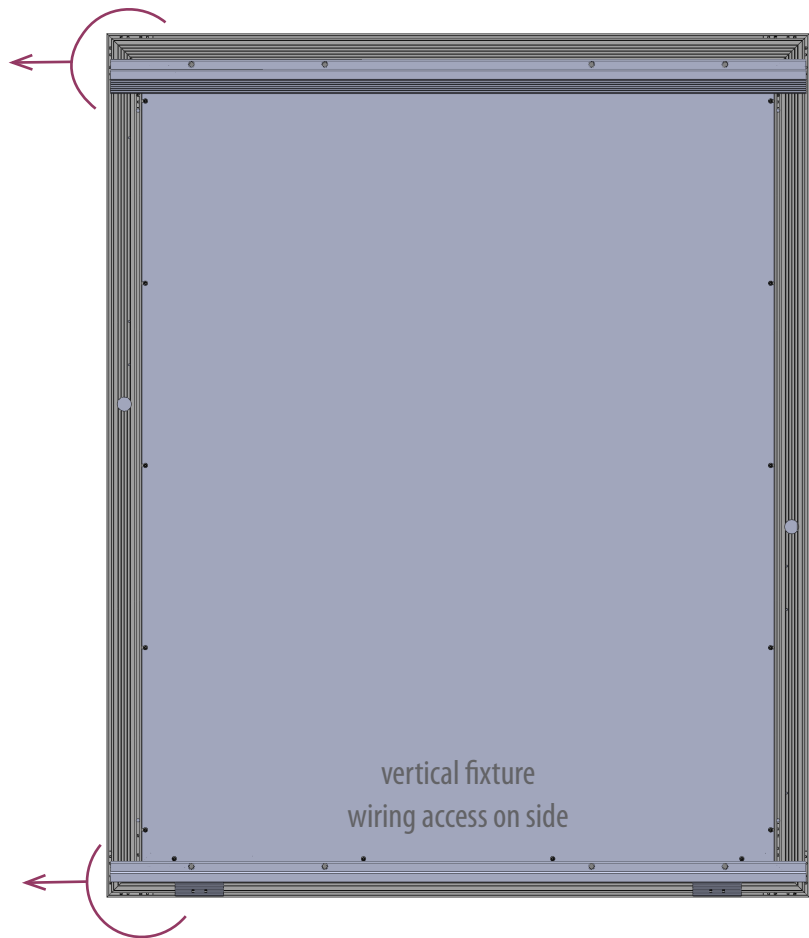
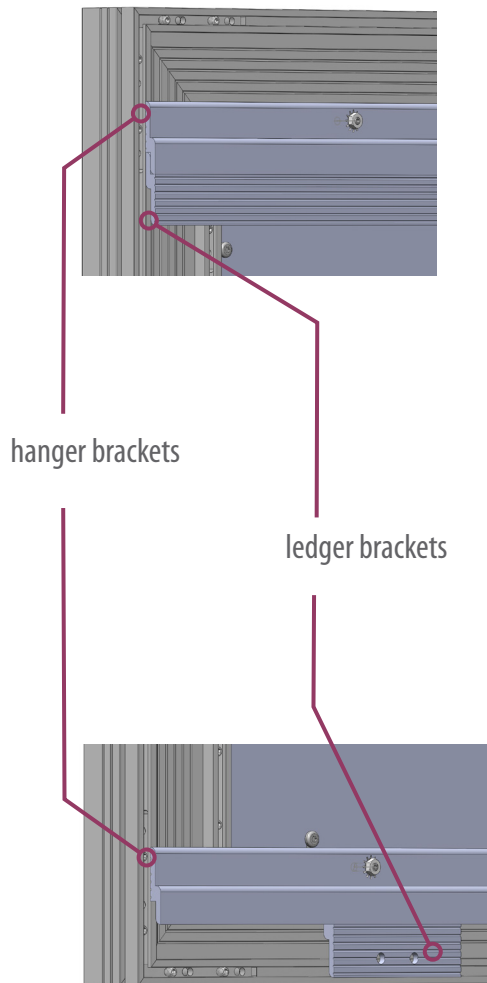

"Ledger" brackets are client-mounted on the wall:

- Top ledger is 1" (25mm) shorter than width of case and is centered on fixture
- Two bottom ledgers are 3" (76mm) long and are mounted with as much spread between them as possible

horizontal fixture
wiring access on bottom

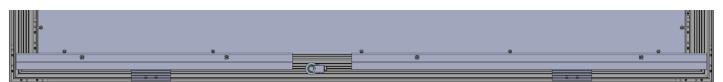

Wall layout detail::

Top ledger —

must be drilled at stud locations

where possible, always attach ledger to at least two studs

where only one stud is available, ledger preferably centered on stud with a 3/16" (9.5mm) toggle at each end.

Bottom ledgers —

attached to studs with as much spread between them as possible

fasteners toenailed using both holes

ledgers mounted so they don't bear weight of fixture

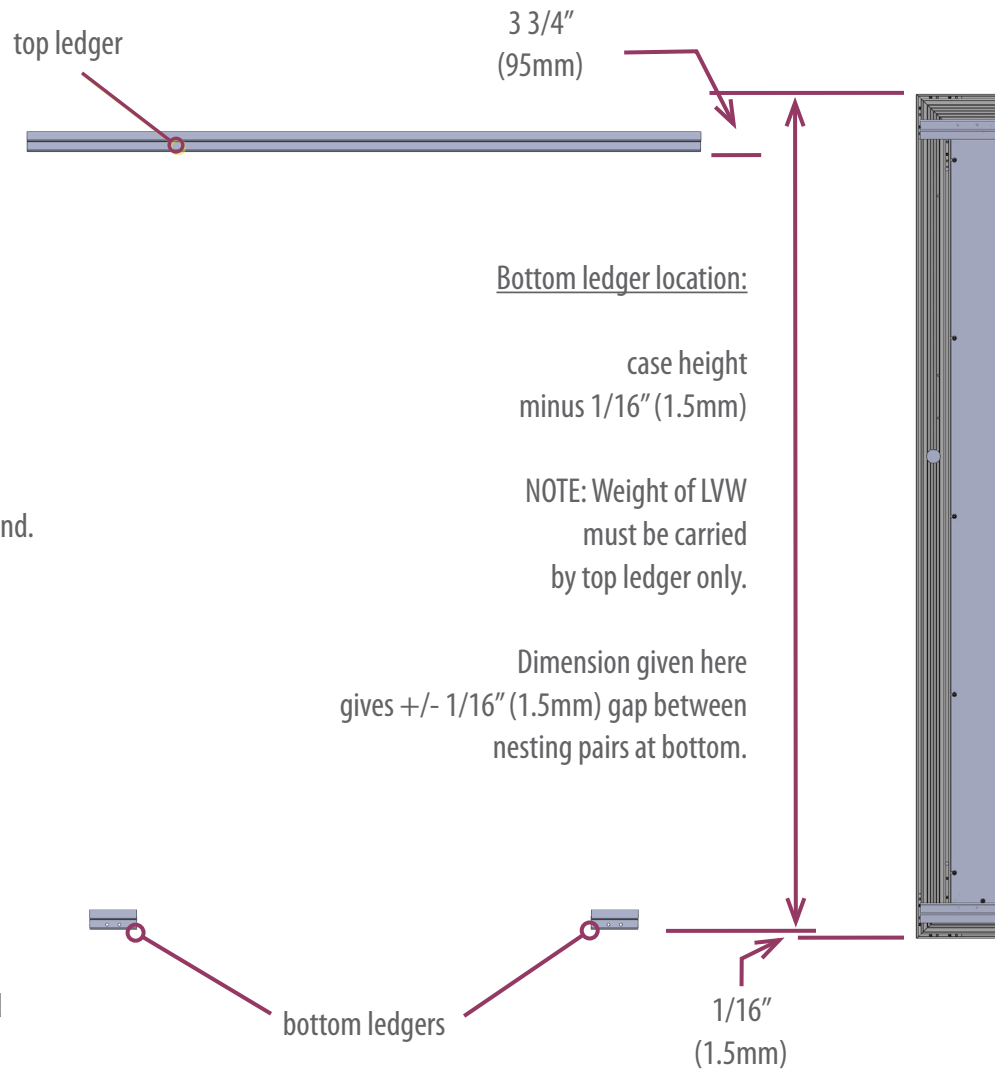

IMPORTANT: Ledger brackets must be mounted flat, plumb, square and dimensionally accurate.

- Ledger brackets must be mounted so LVW is not twisted or trim may not securely latch
Any excessive twist in the installed LVW case may keep some of the ball catches from latching and allow the trim to pop loose.
See "Appendix A: Checking for Flatness" on page 16 for determining if the LVW will sit in a single plane.
- Ledger brackets must be mounted so wall covering is not more than 1/16" (1-1.5mm) forward of back of brackets.
If wall is too far forward, trim will not fully seat on ball catches, and latches may fail causing trim to pop loose.
Use a straight edge to determine the most forward point of the wall surface.

Step 4: Install the LVW

Remove the trim (if provided):

Trim is held by ball catch hardware. Using both hands, grasp the trim and pull it directly away from the LVW case.

Remove the top, bottom and right side wiring covers:

Covers are secured with #6 - 32 Phillips machine screws.

Cover screws need to be loosened only.

**IMPORTANT: WHEN REPLACING THE WIRING COVERS, SNUG SCREWS ONLY!
(OPTIONAL SCREW SLOTS ARE PROVIDED IF A SCREW STRIPS IN CHANNEL.)**

Insert the box connector:

If using a comparable box connector, it must meet local and national codes.

See page 10 for box connector specifications.

Make sure power cable is available and enters the LVW case at the proper location.

Hang the LVW on the wall:

Pass the power cable through the box connector while lifting the LVW into position and hanging it on the interlocking mounting brackets.

IMPORTANT:

Before wiring the LVW, make sure the trim will securely latch.

If the trim is not secure, the LVW may need to be removed and the ledger brackets adjusted.

See bottom of page 8.

Lock mounting brackets:

Nesting mounting brackets **MUST** be locked in place before trim is attached.

Run #10 x 1 1/2" pan head screws through holes in back wall of case at top and bottom.

See hole locations on page 4.



Notice: Mounting brackets **MUST** be locked in place so LVW cannot shift or be knocked loose.

Step 5: Wire the LVW

- See Wiring Diagrams on pages 14-15



Notice:

The LED lights in the fixture are 24V DC only.

Connect V AC to **BLACK** and **WHITE** pigtails on the power supply mounted inside the case.

Connecting the V AC input to any other type of connector in the fixture will destroy the LED's.

Each LVW has internal 24 V DC power supplies pre-wired at the Sky Factory.

Each power supply is 100-277 V AC, 0.6A at 115V AC, 50/60 Hz.

For power consumption, see: LVW Technical Specifications for standard sizes, LVW1 for custom sizes

V AC power is connected to the power input pigtails:

Line power to **BLACK**, Neutral to **WHITE**, Ground to **GREEN/YELLOW** Earth pigtail.

A wiring cover must be removed to access input pigtails.

Always turn circuit off before removing a wiring cover.

#6 - 32 Phillips machine screws need to be loosened only

When replacing the cover, make sure all mounting screws are tight.

IMPORTANT: WHEN REPLACING THE WIRING COVERS, SNUG SCREWS ONLY!

DO NOT OVERTIGHTEN SCREWS AND STRIP SCREW CHANNEL! (See page 9)

Fasten the provided 1/2" (12.7mm) box connector in the 7/8" (22mm) wiring access hole and make the electrical connection inside the LVW.

Power cable must meet MC/MCI-A or HDFMCI-A specifications; size range .38" (9.65mm) min to .61" (15.49mm) max

Power entry hole is limited to 1/2" nominal trade size conduit.

Connect power (100 – 277V AC) in conformance to local and national Electrical Codes.

Replace the wiring covers and test the fixture before installing the trim.

Step 6: Install the trim

Attach the trim:

Lower the trim onto the LVW case until the ball catches engage and then press the trim against the case.

Make sure trim is secure and all the catches latch before installing the safety screw.

If trim is not secure, wall may be pushing it out. If so, remount LVW case so trim clears wall..

See **Adjusting the ball catches** below if adjustment is necessary.

Insert the safety screw:

Safety screw locks the LVW trim so it can't be jarred loose of the ball catches.

#6-32 x 3/4" Phillips machine screw (provided) is inserted through hole in extension trim at top of LVW

Screw threads into a screw boss on LVW case.

Screw has been pre-threaded at factory. However, press firmly when driving screw to make sure it engages.

IMPORTANT: Screw needs to be snug only. Do not overtighten and strip the threads.

Adjusting the ball catches (if necessary):

IMPORTANT: Ball catches are set at the factory and should not need adjustment in the field. Use the following directions only if absolutely necessary.

To adjust the holding strength of a ball catch -

Loosen or tighten adjustment screws on the two ends of the half attached to the LVW case.

To adjust the location of a ball catch -

Loosen the Phillips head screws holding the catch to the LVW case

slide the catch to the appropriate location in the track, and

re-tighten the screws.

Step 7: Check installation using Final Inspection list.



Is the image evenly lit??

- If there are shadows, dark spots, or bright lines on the image, clean the SkyTile. See LVW Maintenance.

Is the trim securely latched?

- If trim pops off easily, and rubs against wall when it is installed:

LVW case is most likely recessed too far into the wall. Remove LVW and shim between framing additions and back of case.

- If trim pops off easily, and there is a gap between trim and wall all the way around:

Strength of trim ball catches needs to be adjusted.

Is the safety screw installed?

- Install screw.

LUMINOUS VIRTUAL WINDOW DIMENSIONS CHART

For custom sizes, see LVW1 included

LUMINOUS VIRTUAL WINDOW	ACTUAL CASE DIMENSIONS (INCHES)		ACTUAL CASE DIMENSIONS (CM)	
	WIDTH / HEIGHT		WIDTH / HEIGHT	
2240	22	40	55.9	101.6
4022	40	22	101.6	55.9
3440	34	40	86.4	101.6
4034	40	34	101.6	86.4
2852	28	52	71.1	132.1
5228	52	28	132.1	71.1
1864	18	64	45.7	162.6
6418	64	18	162.6	45.7
3464	34	64	86.4	162.6
6434	64	34	162.6	86.4
4872	48	72	121.9	182.9
7248	72	48	182.9	121.9

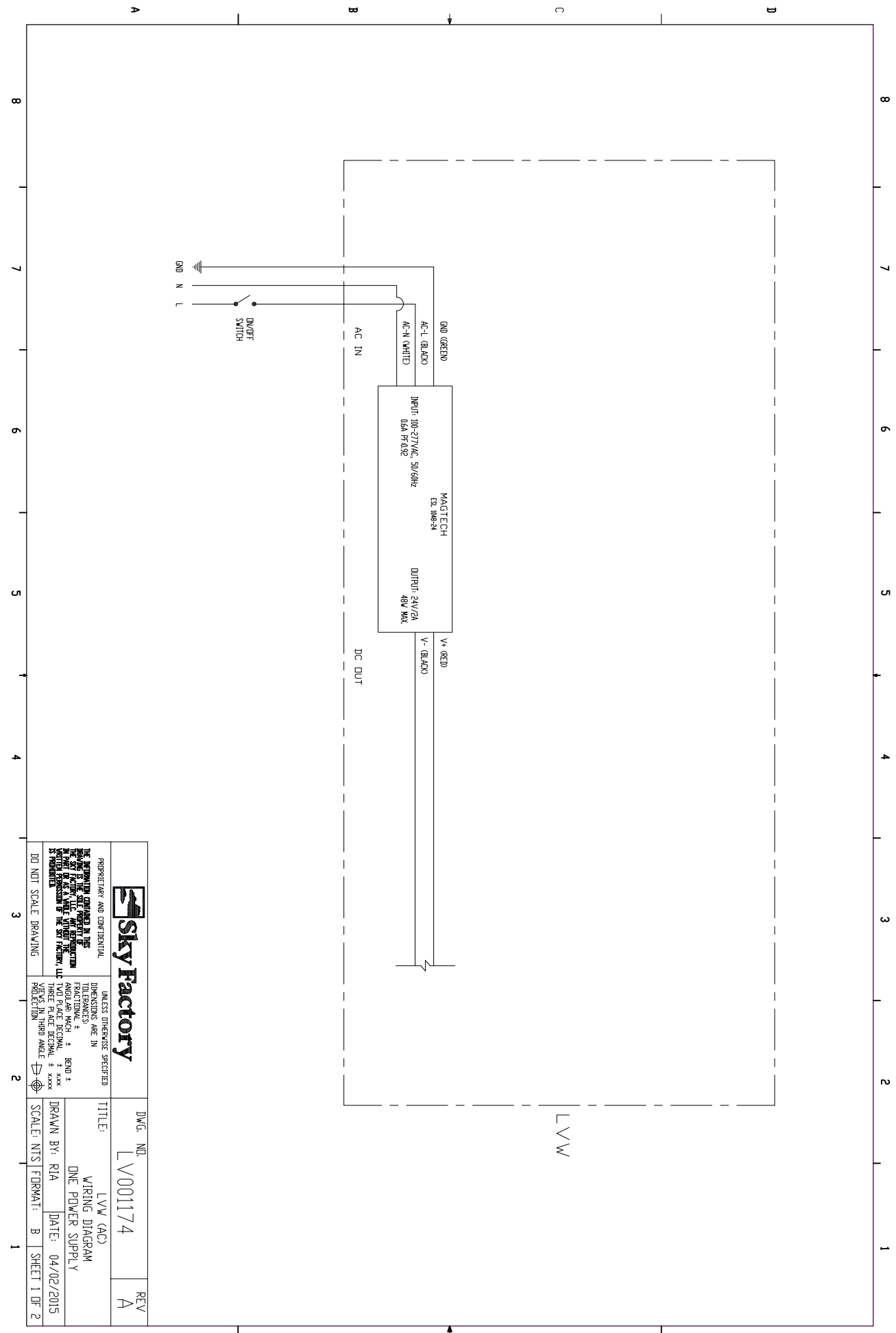

		PROPRIETARY AND CONFIDENTIAL DRAWING IS THE SOLE PROPERTY OF SKY FACTORY, LLC. ANY REPRODUCTION WITHOUT PERMISSION OF THE SKY FACTORY, LLC IS PROHIBITED.	
DO NOT SCALE DRAWING		DIMENSIONS ARE IN FRACTIONS + ANGULARS IN CH + TYPED PLACE DECIMAL + xxx THREE PLACE DECIMAL + xxxxx FRACTION THIRD ANGLE	
DWG. NO.	L V 001174	TITLE:	L V W (AC) WIRING DIAGRAM ONE POWER SUPPLY
REV	A	DRAWN BY:	RIA
		DATE:	04/02/2015
		SCALE:	NTS
		FORMAT:	B
		SHEET	1 OF 2

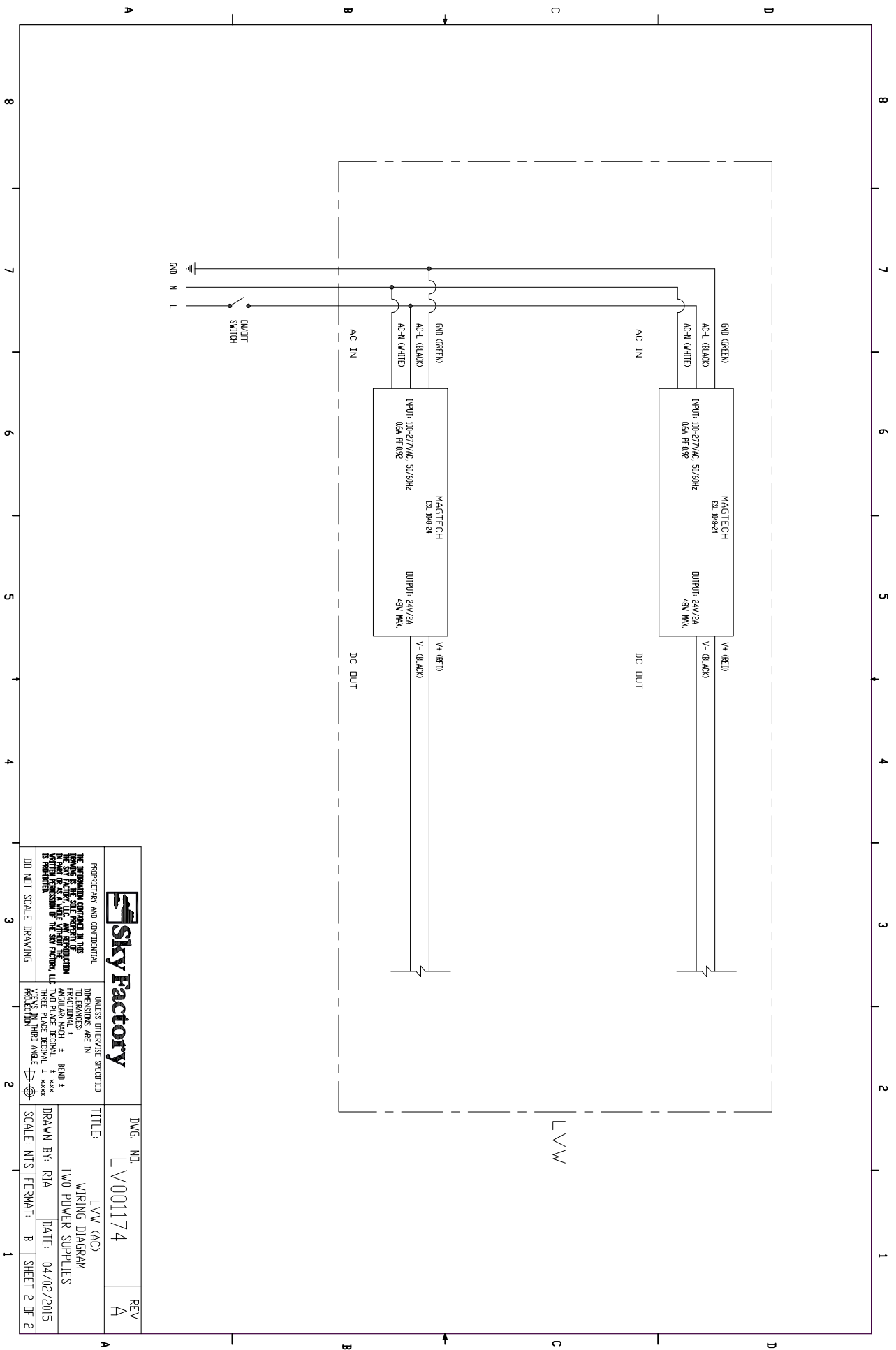

	PROPRIETARY AND CONFIDENTIAL THE INFORMATION CONTAINED IN THIS DRAWING IS THE SOLE PROPERTY OF SKY FACTORY AND IS TO BE USED ONLY FOR THE PROJECT AND IN ACCORDANCE WITH THE TERMS AND CONDITIONS OF THE SKY FACTORY LDC AGREEMENT.	UNLESS OTHERWISE SPECIFIED DIMENSIONS ARE IN FRACTIONAL + ANGULAR DECIMAL + TYPICAL DECIMAL + .xxx VIEWS IN THIRD ANGLE PROJECTION	DWG. NO.	REV
			L V001174	A
TITLE: L VV (AC) WIRING DIAGRAM TWO POWER SUPPLIES		DRAWN BY: RJA DATE: 04/02/2015 SCALE: NTS FORMAT: B SHEET 2 OF 2		

Appendix A: Checking for flatness

Making sure the LVW will sit in a single plane:

Hold a builder's level against the ledger brackets to make sure the two vertical sides have equal plumb.

NOTE: The window does not have to sit plumb in the opening to function properly, but must sit in a single plane.

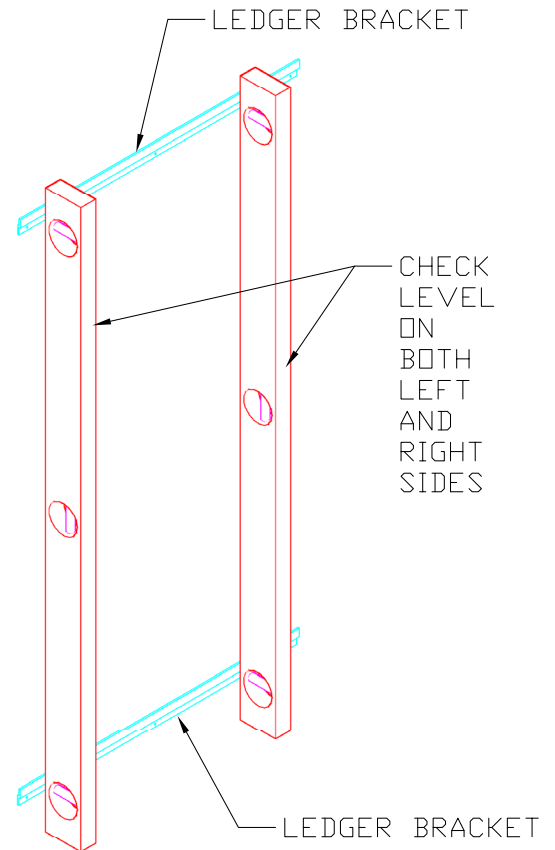

Bubbles on the builder's level must read the same for both vertical sides.

If the two sides do not read the same, shim brackets accordingly.

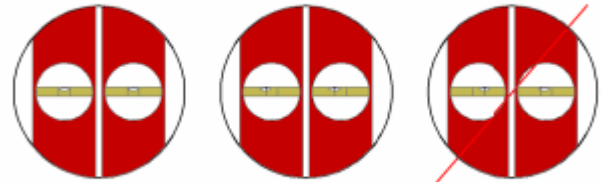

Making sure the LVW is sitting in a single plane:

Use a builder's level against the LVW case to make sure the two vertical sides have equal plumb. Shim case as necessary.

IMPORTANT: Make sure level is sitting parallel to LVW case before checking for equal plumb.