

Revelation w/ EcoSlim Electrical Instructions (HLG)

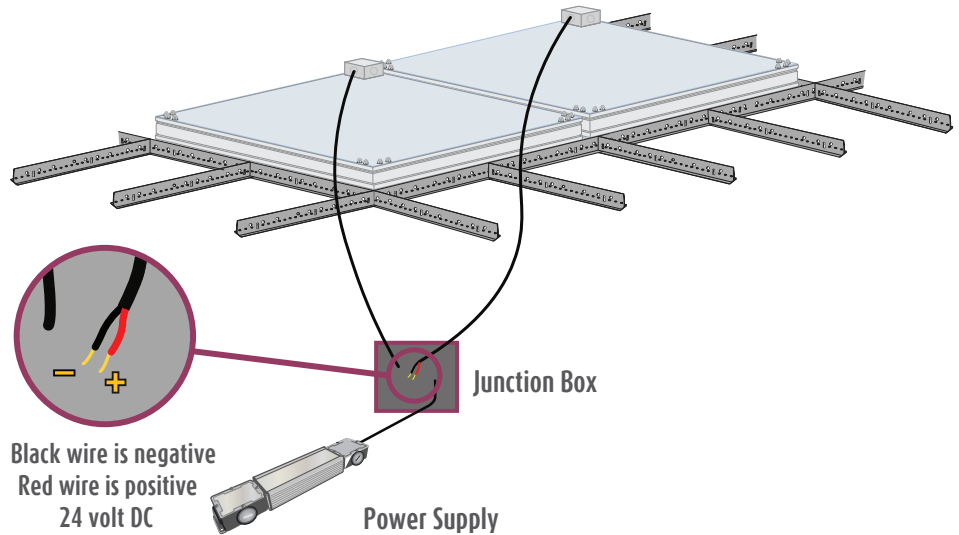

Installation Instructions includes:

Revelation w/ EcoSlim Electrical Instructions (HLG)

Wiring Diagram EL001391, EL001428 & EL001453

Installation specific wiring diagram (where applicable)

For technical support at any time during the installation, please call us **toll free at 866-759-3228**.
We want your installation to go as smoothly as possible. Thank you for choosing Sky Factory.

Revelation w/ EcoSlim Electrical Requirements:

ES24 Series = ES24, ES24M, ES24G

ES26 Series = ES26, ES26M, ES26G

ES33 Series = ES33, ES33M, ES33G

ES34 Series = ES34, ES34M, ES34G

ES36 Series = ES36, ES36M, ES36G

ES44 Series = ES44, ES44M, ES44G

ES46 Series = ES46, ES46M, ES46G

NOTE: For custom sizes, see installation specific wiring diagram included (where applicable)

All EcoSlim fixtures are 24V DC only.

EcoSlim fixtures must be powered only by provided UL Recognized, CE Compliant 24V DC power supply

Dry locations only.

For installations with multiple power supplies, see

installation specific wiring diagram included (where applicable)

For installations with one or more custom sizes, see

installation specific wiring diagram included (where applicable)

RF filter, if used, is not provided by Sky Factory.

Sky Factory provided external dimmable power supply:

Input (Typ) 90-305V, 47 - 63 Hz

Output 24V DC

UL (U.S. and Canada) Recognized and CE Compliant

Maximum Watts (useable) per power supply: 600 Watts

Available sizes: 40W, 60W, 80W, 100W, 120W, 150W, 185W, 240W, 320W, 480W, 600W

AC input wire sizes: 17 AWG on 40-600W

DC output wire sizes: 17 AWG on 40-240W,480W; 14 AWG on 320W,600W

Dimmer wire sizes: 20 AWG on 40-480W; 18 AWG on 600W

Power supply must have 2" clearance for air flow. A 4-6" (10-15cm) clearance must be kept when the adjacent device is a heat source

Power supply must be mounted in dry locations. Wall mount recommended.

Surface mountable

Revelation w/ EcoSlim Electrical Requirements (cont'd):

Sky Factory provided dimmer control (where specified):

Lutron Diva DVSTV 0 - 10V dimmer/switch (UL & CSA compliant)

Input: auto-ranging 120 - 277V AC

Mounts in standard single-gang electrical box

White standard, other colors available on request

Lutron Diva DVTV 0 - 10V dimmer/switch and PP-DV power pack (UL & CSA compliant)

Input: auto-ranging 120 - 277V AC

Lutron Diva mounts in standard single-gang electrical box

White standard, other colors available on request

Jung 240-10 dimmer/switch and external relay where specified (CE compliant)

Input: 230 - 240V AC

Installs in appliance box to DIN 49073

Helvar TK4 140 dimmer/switch (CE compliant)

Input: 220 - 240V AC

Mounts in standard UK or DIN back box

For dimming requirements, see page 6

For dimmer wiring diagrams, see dimmer control (and relay where specified) and wiring diagrams included

Electrical work must be performed by a qualified electrician who is familiar with DC lighting systems and must conform to all local and national codes.

Non-Dimmable and Dimmable Certification:

ES22 Series, ES24 Series, ES26 Series, ES33 Series, ES34 Series, ES36 Series, ES44 Series, ES46 Series, ESCST Series, EP22 Series, EP24 Series, EP26 Series, EP33 Series, EP34 Series, EP36 Series, EP44 Series, EP46 Series, EP55 Series and EPCST Series fixtures when used with 24PS HLG Power System UL, CSA and CE Listed by Intertek Group plc

Step 1: Wiring the Revelation fixtures to the power supply

See wiring diagrams on pages 7-9 and installation specific wiring diagram included (where applicable)

EcoSlim Lighting System - ES24 Series to ES46 Series				
TSF Model No.	Light Box Dimensions and Weight Only		System Wattage (Max)	Input Current @ 24 Volts DC
	WxLxH	Weight		
ES24	22.8125 x 46.8125 x 3.72 (inches)	17.6 lb	36.72	1.53A
ES26	22.8125 x 34.8125 x 3.72 (inches)	27.6 lb	57.1	2.38A
ES33	34.8125 x 34.8125 x 3.72 (inches)	20.8 lb	42.7	1.78A
ES34	34.8125 x 46.8125 x 3.72 (inches)	27.6 lb	52.6	2.19A
ES36	34.8125 x 70.8125 x 3.72 (inches)	40 lb	65.5	2.73A
ES44	46.8125 x 46.8125 x 3.72 (inches)	35.3 lb	59	2.46A
ES46	46.8125 x 70.8125 x 3.72 (inches)	47.5 lb	89.8	3.74A
ES24M	57 x 117 x 9.54 (cm)	7.8 kg	36.72	1.53A
ES26M	57 x 177 x 9.54 (cm)	12.6 kg	57.1	2.38A
ES33M	87 x 87 x 9.54 (cm)	9.5 kg	42.7	1.78A
ES34M	87 x 117 x 9.54 (cm)	12.6 kg	52.6	2.19A
ES36M	87 x 177 x 9.54 (cm)	18.1 kg	65.5	2.73A
ES44M	117 x 117 x 9.54 (cm)	16 kg	59	2.46A
ES46M	117 x 177 x 9.54 (cm)	21.1 kg	89.8	3.74A
ES24G	59.5 x 122 x 9.54 (cm)	8.3kg	36.72	1.53A
ES26G	59.5 x 184.5 x 9.54 (cm)	12.6 kg	57.1	2.38A
ES33G	90.8 x 90.8 x 9.54 (cm)	9.5 kg	42.7	1.78A
ES34G	90.8 x 122 x 9.54 (cm)	12.6 kg	52.6	2.19A
ES36G	90.8 x 184.5 x 9.54 (cm)	18.1 kg	65.5	2.73A
ES44G	122 x 122 x 9.54 (cm)	16 kg	59	2.46A
ES46G	122 x 184.5 x 9.54 (cm)	22.4 kg	89.8	3.74A

NOTE: For custom sizes, see also installation specific wiring diagram included (where applicable)



Notice: The LED fixtures are 24V DC ONLY.

AC voltage connected directly to the fixtures
will destroy the lighting system.

Step 1 continued

Fixtures are wired together in single or multiple circuits.

Each circuit is dedicated to a single power system and may be arranged in rows or clusters, depending on installation.

A junction box with 1/2" trade size knock-outs is attached on top corner of each fixture.

- Power leads inside fixture junction box are polarized, red (+) and black (-).
- Larger fixtures may have two sets of leads. When making connections, leads are wired together red (+) to red (+) and black (-) to black (-) unless otherwise specified.
- Where fixtures have multiple junction boxes, see installation specific wiring diagram included.
- Fixture wire size 18 AWG stranded.

Wiring from fixtures to V DC side of provided power supply is polarized, positive (+) to positive (+) and negative (-) to negative (-):

EcoSlim fixture red "+ " to power supply **Vo+**

EcoSlim fixture black "- " to power supply **Vo-**

For power supply V DC wire size, see wiring diagrams included

HLG-480H-24B and HLG-600H-24B have two sets of output leads. Meanwell recommends loading no more than:

240 Watts on each set of cables for HLG-480H-24B

480 Watts on each set of cables for HLG-600H-24B

Wire and additional junction boxes from fixtures to power supply provided by others.

Wire gauge must conform to local and national codes. Voltage drop of no more than 3% is recommended.

Step 2: Wiring the power supply to source V AC

Run power to V AC side of the power supply.

Load to power supply **ACL**

Neutral to power supply **ACN**

Ground to power supply  **(GREEN/YELLOW)**

Wire gauge must conform to local and national codes.

Install the power switch on the V AC input side of the power supply.

Step 3: Dimming requirements

Contact the Sky Factory if you plan on using a dimming system provided by others.



Notice: Dimming using non-approved systems may permanently damage LED's and will void the warranty!

Wiring a Sky Factory provided dimmer control:

To wire the dimmer control (and external relay where specified), refer to wiring diagram included with dimmer and relay and wiring diagrams included.

Step 4: Checking the polarity



Notice: CHECK THE POLARITY BEFORE TURNING ON POWER. MAKE SURE:

Red wires on the fixtures go to the "+" terminals of the power supply

Black wires on the fixtures go to the "-" terminals of the power supply

IF THE SYSTEM IS WIRED BACKWARD, IT WILL DESTROY THE LED'S!

EP AND ES SERIES FIXTURES WITH HLG POWER SUPPLY DIMMING OPTION

- ECOPULS
- EP22 SERIES, EP24 SERIES, EP26 SERIES, EP33 SERIES, EP34 SERIES, EP36 SERIES, EP44 SERIES, EP46 SERIES, EP55 SERIES, EPCST SERIES
- ECOSLIM
- ES22 SERIES, ES24 SERIES, ES26 SERIES, ES33 SERIES, ES34 SERIES, ES36 SERIES, ES44 SERIES, ES46 SERIES, ES55 SERIES, EPCST SERIES

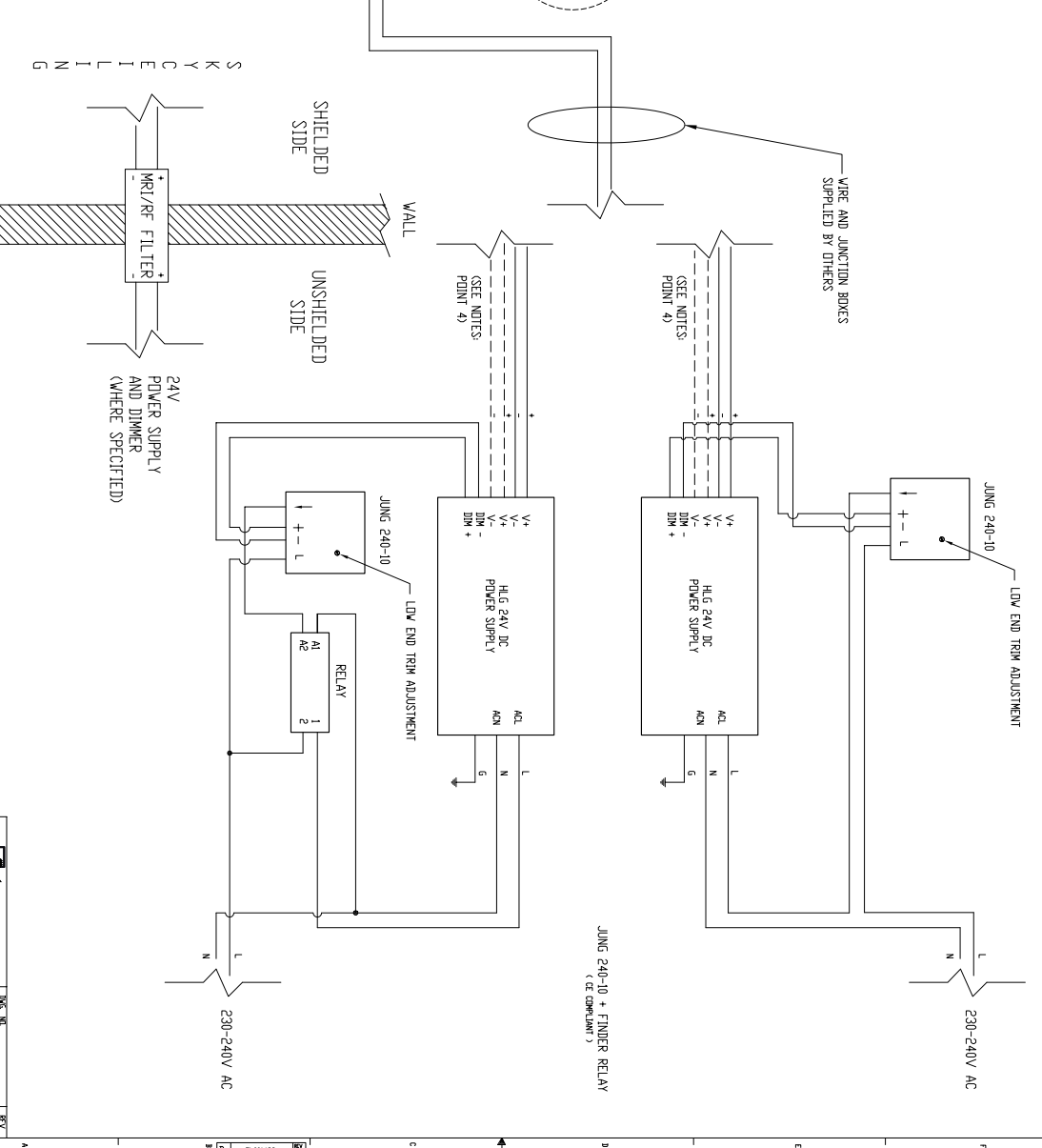
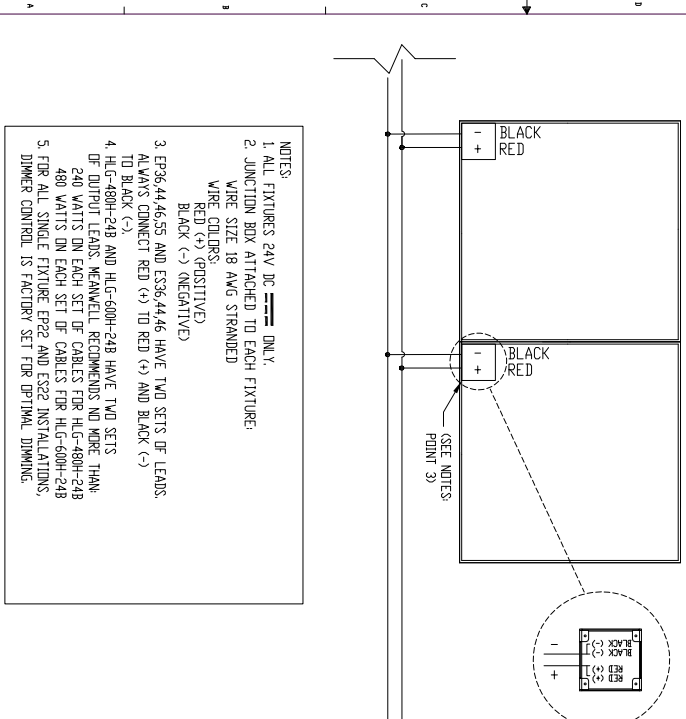

- NOTES:
1. ALL FIXTURES 24V DC ONLY.
 2. JUNCTION BOX ATTACHED TO EACH FIXTURE; WIRE SIZE 18 AWG STRANDED
 3. EP36, EP44, EP55 AND ES36, ES44, ES55 HAVE TWO SETS OF LEADS TO BLACK (-) TO RED (+) AND BLACK (-) TO BLACK (-).
 4. HLG-480H-248 AND HLG-600H-248 HAVE TWO SETS OF OUTPUT LEADS. MEANWELL RECOMMENDS NO MORE THAN 240 WATTS ON EACH SET OF CABLES FOR HLG-480H-248 AND 480 WATTS ON EACH SET OF CABLES FOR HLG-600H-248
 5. FOR ALL SINGLE FIXTURE, EP22 AND ES22 INSTALLATIONS, DIMMER CONTROL IS FACTORY SET FOR OPTIMAL DIMMING.

Sky Factory

MANUFACTURER OF SKYLINE LIGHTING
 10000 WILSON AVENUE
 SUITE 100
 BOSTON, MA 02120
 TEL: 617.261.1111
 FAX: 617.261.1112
 WWW.SKYFACTORY.COM

TITLE: EP AND ES SERIES WITH HLG POWER SUPPLY DIMMING OPTION
 DATE: 06/25/2024
 SHEET: 11 OF 11

